

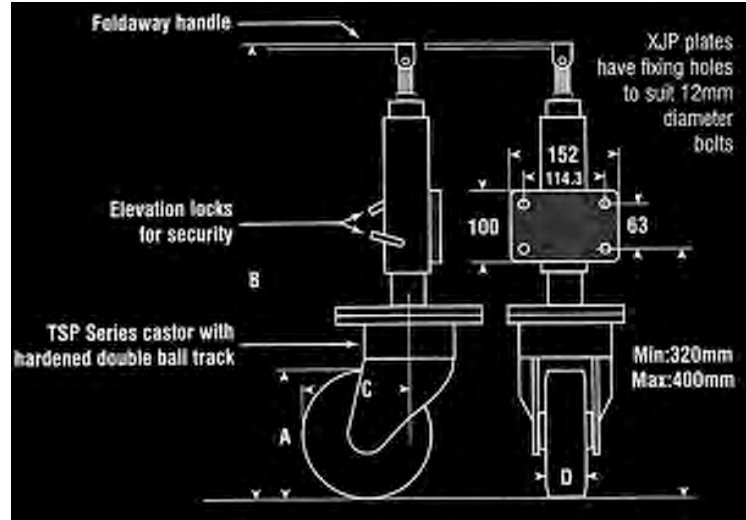

JACKING CASTER

- Easy
- Accurate
- Vertical
- Adjustment



Wheels Made of
Vulkollan™
 or
Nylacron™

25.4 mm	=	1"
63 mm	=	2-1/2"
100 mm	=	4"
114.3 mm	=	4-1/2"
152 mm	=	6"
320 mm	=	12.60"
400 mm	=	15.75"

XPJ 200 Lifting Jack Caster

Diameter (mm / in)	OAH (mm / in)	Swivel Radius (mm / in)	Tread Width (mm / in)	Wheel Type	Capacity (lb)	Swivel Part Number
200 / 8	635 / 25	172 / 6-3/4	50 / 2	Rubber / Cast Iron Core (RY/CA)	1180	XPJ/R/CA-200/50/PB-S
200 / 8	635 / 25	172 / 6-3/4	45 / 1-3/4	Vulkollan™ / Cast Iron Core (VU/CA)	2200	XPJ/VU/CA-200/45/PB-S
200 / 8	635 / 25	172 / 6-3/4	45 / 1-3/4	Vulkollan™ (VU)	2200	XPJ/VU-200/45/PB-S
200 / 8	635 / 25	172 / 6-3/4	45 / 1-3/4	Nylacron™ (NY/MD)	2200	XPJ/NY/MD-200/45/PB-S
200 / 8	635 / 25	172 / 6-3/4	45 / 1-3/4	Nylacron™ Monocast (NY/MC)	2200	XPJ/NY/MC-200/45/PB-S

“FOUR-IN-ONE” CASTER JACKS—SERIES 31008

- 1. LIFT 2. LOWER 3. SWIVEL 4. ROLL**



Jack without
Wheels

Use Saginaw casterjacks when you need lifting ability combined with mobility. These special jacks incorporate the use of heavy duty inner tube assemblies which enable you to obtain the stated side load capability needed for full casterjack extension. *All 31008 series casterjacks are furnished without the caster.* This option allows you to choose a caster style which will meet your specific requirements.

Casters are available from Saginaw Products Corporation with various types of

tire treads, wheel brakes, position locks, and offset and non-offset configuration. Special care must be taken when selecting your caster requirement to make certain you do not exceed the maximum allowable caster size specified for each individual casterjack assembly. Usable side load capability is a factor of the rated load, overall height, and the swivel offset of the caster assembly selected. If your casterjack requirements exceed 1,800 pounds capacity, please contact Saginaw Products Corporation for assistance.



Jack with
Nylacron™ Wheel

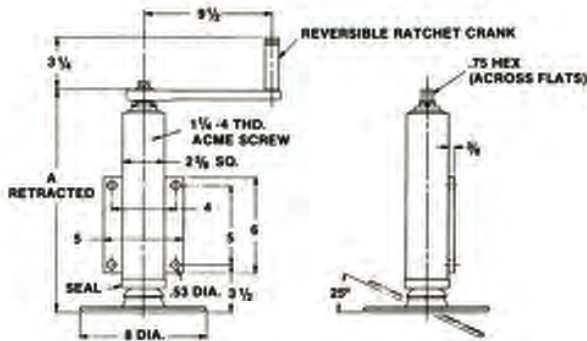

1800 LBS. CAPACITY — RIGID MOUNT

SAGINAW PART NO.	STROKE	A	*SIDE LOAD LB.	WGT.
31050-6	6	16	1200	18
31050-12	12	22	700	25
31050-18	18	28	500	32

NOTE: *Maximum static side load to yield, combined with maximum operating load. Unit must be securely fixed at mounting point of jack side plate to frame member.

BASIC DATA:

- 4 revs. input for 1 inch of stroke.
- 1,800 lb. maximum operating load, compression.
- 4,500 lb. maximum static compression to yield.
- Approx. 240 inch lb. torque input at maximum operating load.
- Furnished with 8 inch crank as shown.

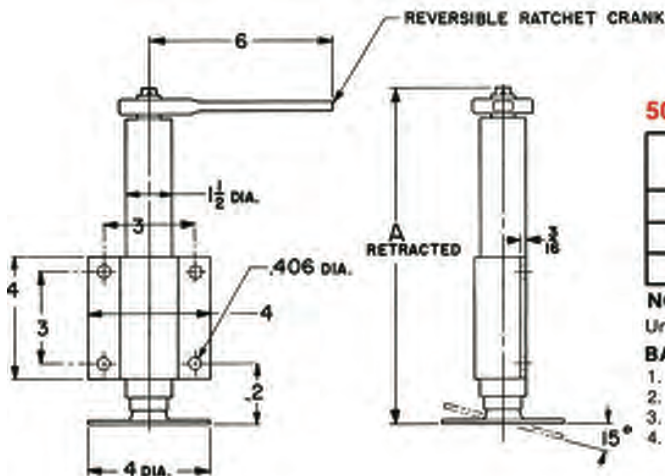

500 LBS. CAPACITY — RIGID MOUNT

SAGINAW PART NO.	STROKE	A	*SIDE LOAD LB.	WGT.
31060-3	3	10	800	5
31060-6	6	13	450	7
31060-9	9	16	300	9

NOTE: *Maximum static side load to yield, combined with maximum operating load. Unit must be securely fixed at mounting point of jack side plate to frame member.

BASIC DATA:

- 6 revs. input for 1 inch of stroke.
- 500 lb. maximum operating load, compression.
- 4,000 lb. maximum static compression to yield.
- Approx. 80 inch lb. torque input at maximum operating load.

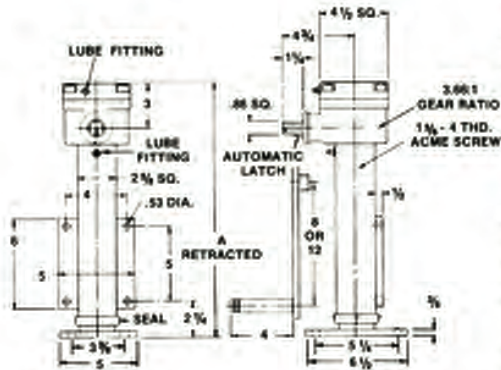

BASIC DATA:

1. 14.6 revs. input for 1 inch of stroke.
2. 1800 lb. maximum operating load, compression.
3. Approx. 80 inch lb. torque input at maximum operating load.
4. Specify crank: 8 inch, Part No. 10582-K, or 12 inch, Part No. 10582-M.

****7500 LBS. CAPACITY FIXED PAD JACK (WITHOUT CASTER)**

JACK DATA	SAGINAW PART NO.	STROKE	A	WEIGHT LESS CASTER	*SIDE LOAD LB.
	31038-3	3	13-3/4	41-1/2	725
	31038-6	6	16-3/4	45	600
	31038-12	12	22-3/4	52	450
	31038-18	18	28-3/4	59	350

1800 LBS. CAPACITY CASTERJACK (WITH CASTER)

CASTER DATA	SAGINAW PART NO.	MAX. CAPACITY LBS.	MAX. CASTER HEIGHT	MAX. OFFSET	BOLT HOLE SPACING	BOLT DIA.
	31038-3	1800	10-5/16	2-1/2	3-3/8 x 5-1/4	1/2
	31038-6					
	31038-12					
	31038-18					

NOTE: *Side load capacity based on 1800 lbs. load with jack at full extension and with caster mounted having a maximum overall height of 10-5/16" and 2-1/2" swivel offset. Unit must be securely fixed at point of jack side plate, and also between jack base plate and caster top plate.
 **See basic data for 31030 jack assemblies when using unit less caster.

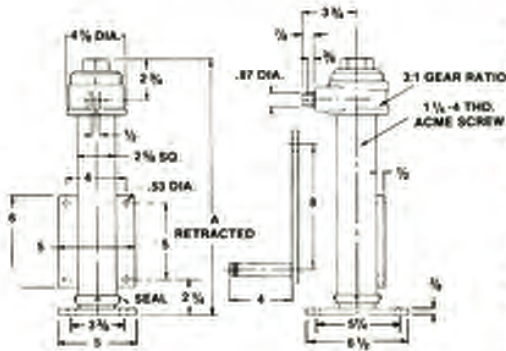

BASIC DATA:

1. 12 revs. input for 1 inch of travel.
2. 1800 lb. maximum operating load, compression.
3. Approx. 95 inch lb. torque input at maximum operating load.
4. Furnished with 8 inch crank, Part No. 14168-4.

****5000 LBS. CAPACITY FIXED PAD JACK (WITHOUT CASTER)**

JACK DATA	SAGINAW PART NO.	STROKE	A	WEIGHT LESS CASTER	*SIDE LOAD LB.
	31048-3	3	13-5/8	31-1/2	725
	31048-6	6	16-5/8	35	600
	31048-12	12	22-5/8	42	450
	31048-18	18	28-5/8	49	350

1800 LBS. CAPACITY CASTERJACK (WITH CASTER)

CASTER DATA	SAGINAW PART NO.	MAX. CAPACITY LBS.	MAX. CASTER HEIGHT	MAX. OFFSET	BOLT HOLE SPACING	BOLT DIA.
	31048-3	1800	10-5/16	2-1/2	3-3/8 x 5-1/4	1/2
	31048-6					
	31048-12					
	31048-18					

NOTE: *Side load capacity based on 1800 lbs. load with jack at full extension and with caster mounted having a maximum overall height of 10-5/16" and 2-1/2" swivel offset. Unit must be securely fixed at point of jack side plate, and also between jack base plate and caster top plate.
 **See basic data for 31040 jack assemblies when using unit less caster.

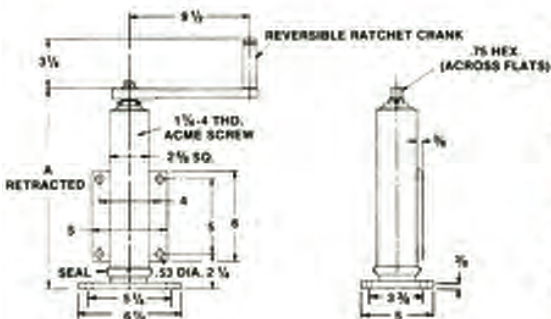

BASIC DATA:

1. 4 revs. input for 1 inch of stroke.
2. 1800 lb. maximum operating load, compression.
3. Approx. 240 inch lb. torque input at maximum operating load.
4. Furnished with 9-1/2 inch crank as shown.

****1800 LBS. CAPACITY FIXED PAD JACK (WITHOUT CASTER)**

JACK DATA	SAGINAW PART NO.	STROKE	A	WEIGHT LESS CASTER	*SIDE LOAD LB.
	31058-3	3	12	16	725
	31058-6	6	15	23	600
	31058-12	12	21	30	450
	31058-18	18	27	38	350

1800 LBS. CAPACITY CASTERJACK (WITH CASTER)

CASTER DATA	SAGINAW PART NO.	MAX. CAPACITY LBS.	MAX. CASTER HEIGHT	MAX. OFFSET	BOLT HOLE SPACING	BOLT DIA.
	31058-3	1800	10-5/16	2-1/2	3-3/8 x 5-1/4	1/2
	31058-6					
	31058-12					
	31058-18					

NOTE: *Side load capacity based on 1800 lbs. load with jack at full extension and with caster mounted having a maximum overall height of 10-5/16" and 2-1/2" swivel offset. Unit must be securely fixed at point of jack side plate, and also between jack base plate and caster top plate.
 **See basic data for 31050 jack assemblies when using unit less caster.

31000 SERIES JACKS

Seven basic models that meet most every lifting requirement up to 10,000 pounds.

FEATURES:

1. **VERSATILE** ... jacks can operate vertically or horizontally to raise, lower or push your load. Units requiring tension load capability are available on special application.
2. **COMPACT** ... single package unit does away with cylinders or other space consuming arrangements.
3. **COMPLETE PROTECTION OF SCREW AND CRITICAL PARTS** ... by inner and outer tube enclosure. Round tubes in 10,000 lb. models assure precision fit and extreme mounting rigidity. Other models have square tube construction. Special tube locks available where side movement must be completely eliminated.
4. **AUTOMATIC LATCH AND SELF-LOCKING DESIGN** ... provides double safety against rotation of jack screw under vibration or extreme loading conditions. No need for brakes or expensive locking devices. Automatic latch is standard in 7,500 lb. and 10,000 lb. models. Latch actuates when crank handle is removed from assembly.
5. **CAN TAKE SIDE LOADS** ... resulting from uneven terrain, off-center loading, and eccentric mounting methods.
6. **HIGH EFFICIENCY BEVEL GEARHEADS** ... with 3:1 or 3.66:1 gear ratios in 5,000 lb., 7,500 lb., and 10,000 lb. models. Gearheads have precision tapered thrust bearings, steel or bronze driveshaft bushings, large lubricant reservoir. 500 lb. and 1,800 lb. models operate on direct screw drive.
7. **STOWABLE** ... solves ground clearance problems. Trunnion mount 31000 and 31020 models swing up and out of the way ... are easily attached to trailer in the horizontal position.
8. **CORROSION-RESISTANT FINISH** ... all jacks are treated with protective phosphate to Mil-P-16232 and are prime painted with red oxide per Mil-TT-P-636. All hardware is zinc or cadmium plated.

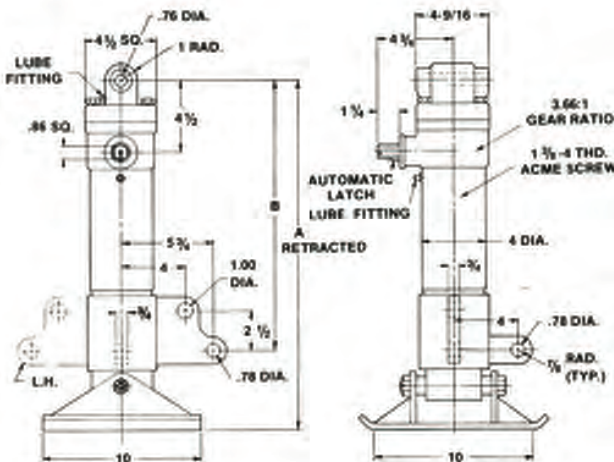

10000 LBS. CAPACITY — STOWABLE

SAGINAW PART NO.	STROKE	A	B	*SIDE LOAD LB.	WGT.
31000-6 L or R	6	22	17	11600	71
31000-12 L or R	12	28	23	7000	83
31000-18 L or R	18	34	29	5000	95

NOTE: *Maximum static side load to yield, combined with maximum operating load. Unit must be securely fixed at connecting points.

BASIC DATA:

1. 14.6 revs. input for 1 inch of stroke.
2. 10,000 lb. maximum operating load, compression.
3. 25,000 lb. maximum static compression to yield.
4. Approx. 380 inch lb. torque input at maximum operating load.
5. Specify crank: 8 inch, Part No. 10582-K or 12 inch, Part No. 10582-M

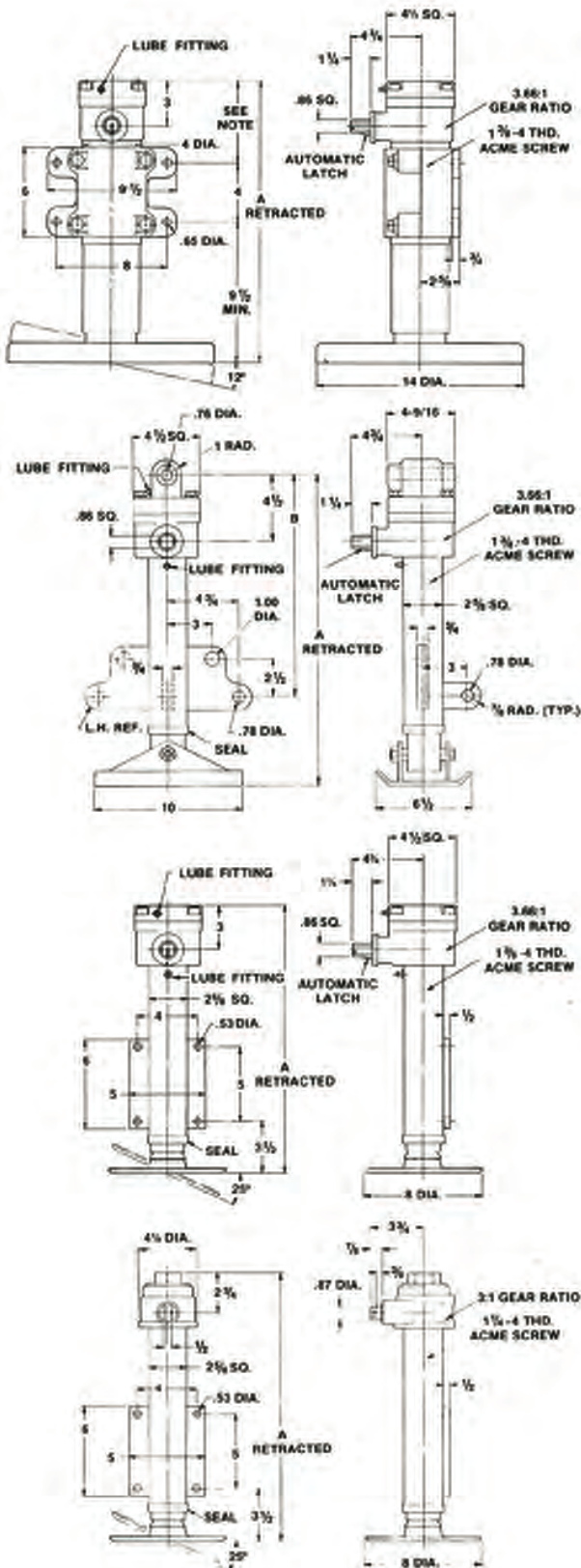

10000 LBS. CAPACITY — RIGID MOUNT

SAGINAW PART NO.	STROKE	A	*SIDE LOAD LB.	WGT.
31010-6	6	19	6300	86
31010-12	12	25	3600	98
31010-18	18	31	2500	110

NOTE: *Maximum static side load to yield, combined with maximum operating load. Unit must be securely fixed at mounting point of jack side plate to frame member. Adjustable clamp bracket may be adjusted along entire length of tube toward gear head on -12 to -18 models. As a precaution it is advisable to weld bracket to outer tube, on all units, after location of proper mounting height is determined to prevent possible slippage.

BASIC DATA:

- 14.5 revs. input for 1 inch of stroke.
- 10,000 lb. maximum operating load, compression.
- 25,000 lb. maximum static compression to yield.
- Approx. 380 inch lb. torque input at maximum operating load.
- Specify crank: 8 inch, Part No. 10582-K or 12 inch, Part No. 10582-M.

7500 LBS. CAPACITY — STOWABLE

SAGINAW PART NO.	STROKE	A	B	*SIDE LOAD LB.	WGT.
31020-6 L or R	6	21	15	850	45
31020-12 L or R	12	27	21	500	52
31020-18 L or R	18	33	27	400	59

NOTE: *Maximum static side load to yield, combined with maximum operating load. Unit must be securely fixed at connecting points.

BASIC DATA:

- 14.6 revs. input for 1 inch of stroke.
- 7,500 lb. maximum operating load, compression.
- 22,000 lb. maximum static compression to yield.
- Approx. 285 inch lb. torque input at maximum operating load.
- Specify crank: 8 inch, Part No. 10582-K or 12 inch, Part No. 10582-M.
- Available with 14" dia. all terrain foot pad. Specify Part No. 31022-8 etc.

7500 LBS. CAPACITY — RIGID MOUNT

SAGINAW PART NO.	STROKE	A	*SIDE LOAD LB.	WGT.
31030-6	6	18	1100	45
31030-12	12	24	600	52
31030-18	18	30	400	59

NOTE: *Maximum static side load to yield, combined with maximum operating load. Unit must be securely fixed at mounting point of jack side plate to frame member.

BASIC DATA:

- 14.6 revs. input for 1 inch of stroke.
- 7,500 lb. maximum operating load, compression.
- 22,000 lb. maximum static compression to yield.
- Approx. 285 inch lb. torque input at maximum operating load.
- Specify crank: 8 inch, Part No. 10582-K or 12 inch, Part No. 10582-M.

5000 LBS. CAPACITY — RIGID MOUNT

SAGINAW PART NO.	STROKE	A	*SIDE LOAD LB.	WGT.
31040-6	6	18	1100	35
31040-12	12	24	600	42
31040-18	18	30	400	49

NOTE: *Maximum static side load to yield, combined with maximum operating load. Unit must be securely fixed at mounting point of jack side plate to frame member.

BASIC DATA:

- 12 revs. input for 1 inch of stroke.
- 5,000 lb. maximum operating load, compression.
- 15,000 lb. maximum static compression to yield.
- Approx. 235 inch lb. torque input at maximum operating load.
- Furnished with 8 inch crank, Part No. 14168-4.