

Sure^{step}™ Stepping Systems

User Manual

Manual #: **STP-SYS-M-W0**
2nd Ed, Rev A

STP-DRV-xxxx
Microstepping Drives



STP-PWR-xxxxx
Stepping System
Power Supplies



STP-MTR(H)-xxxx
Connectorized Bipolar Stepping Motors



STP-EXT(H)-020
Step Motor Extension Cable

THIS PAGE
INTENTIONALLY
LEFT BLANK

⚡ WARNING ⚡

Thank you for purchasing automation equipment from Automationdirect.com®, doing business as AutomationDirect. We want your new automation equipment to operate safely. Anyone who installs or uses this equipment should read this publication (and any other relevant publications) before installing or operating the equipment.

To minimize the risk of potential safety problems, you should follow all applicable local and national codes that regulate the installation and operation of your equipment. These codes vary from area to area and usually change with time. It is your responsibility to determine which codes should be followed, and to verify that the equipment, installation, and operation is in compliance with the latest revision of these codes.

At a minimum, you should follow all applicable sections of the National Fire Code, National Electrical Code, and the codes of the National Electrical Manufacturer's Association (NEMA). There may be local regulatory or government offices that can also help determine which codes and standards are necessary for safe installation and operation.

Equipment damage or serious injury to personnel can result from the failure to follow all applicable codes and standards. We do not guarantee the products described in this publication are suitable for your particular application, nor do we assume any responsibility for your product design, installation, or operation.

Our products are not fault-tolerant and are not designed, manufactured or intended for use or resale as on-line control equipment in hazardous environments requiring fail-safe performance, such as in the operation of nuclear facilities, aircraft navigation or communication systems, air traffic control, direct life support machines, or weapons systems, in which the failure of the product could lead directly to death, personal injury, or severe physical or environmental damage ("High Risk Activities"). AutomationDirect specifically disclaims any expressed or implied warranty of fitness for High Risk Activities.

For additional warranty and safety information, see the Terms and Conditions section of our catalog. If you have any questions concerning the installation or operation of this equipment, or if you need additional information, please call us at 770-844-4200.

This publication is based on information that was available at the time it was printed. At AutomationDirect we constantly strive to improve our products and services, so we reserve the right to make changes to the products and/or publications at any time without notice and without any obligation. This publication may also discuss features that may not be available in certain revisions of the product.

Trademarks

This publication may contain references to products produced and/or offered by other companies. The product and company names may be trademarked and are the sole property of their respective owners. AutomationDirect disclaims any proprietary interest in the marks and names of others.

**Copyright 2004, 2007, 2008, 2009, Automationdirect.com® Incorporated
All Rights Reserved**

No part of this manual shall be copied, reproduced, or transmitted in any way without the prior, written consent of Automationdirect.com® Incorporated. AutomationDirect retains the exclusive rights to all information included in this document.

⚡ AVERTISSEMENT ⚡

Nous vous remercions d'avoir acheté l'équipement d'automatisation de Automationdirect.com®, en faisant des affaires comme AutomationDirect. Nous tenons à ce que votre nouvel équipement d'automatisation fonctionne en toute sécurité. Toute personne qui installe ou utilise cet équipement doit lire la présente publication (et toutes les autres publications pertinentes) avant de l'installer ou de l'utiliser.

Afin de réduire au minimum le risque d'éventuels problèmes de sécurité, vous devez respecter tous les codes locaux et nationaux applicables régissant l'installation et le fonctionnement de votre équipement. Ces codes diffèrent d'une région à l'autre et, habituellement, évoluent au fil du temps. Il vous incombe de déterminer les codes à respecter et de vous assurer que l'équipement, l'installation et le fonctionnement sont conformes aux exigences de la version la plus récente de ces codes.

Vous devez, à tout le moins, respecter toutes les sections applicables du Code national de prévention des incendies, du Code national de l'électricité et des codes de la National Electrical Manufacturer's Association (NEMA). Des organismes de réglementation ou des services gouvernementaux locaux peuvent également vous aider à déterminer les codes ainsi que les normes à respecter pour assurer une installation et un fonctionnement sûrs.

L'omission de respecter la totalité des codes et des normes applicables peut entraîner des dommages à l'équipement ou causer de graves blessures au personnel. Nous ne garantissons pas que les produits décrits dans cette publication conviennent à votre application particulière et nous n'assumons aucune responsabilité à l'égard de la conception, de l'installation ou du fonctionnement de votre produit.

Nos produits ne sont pas insensibles aux défaillances et ne sont ni conçus ni fabriqués pour l'utilisation ou la revente en tant qu'équipement de commande en ligne dans des environnements dangereux nécessitant une sécurité absolue, par exemple, l'exploitation d'installations nucléaires, les systèmes de navigation aérienne ou de communication, le contrôle de la circulation aérienne, les équipements de survie ou les systèmes d'armes, pour lesquels la défaillance du produit peut provoquer la mort, des blessures corporelles ou de graves dommages matériels ou environnementaux («activités à risque élevé»). La société AutomationDirect nie toute garantie expresse ou implicite d'aptitude à l'emploi en ce qui a trait aux activités à risque élevé.

Pour des renseignements additionnels touchant la garantie et la sécurité, veuillez consulter la section Modalités et conditions de notre documentation. Si vous avez des questions au sujet de l'installation ou du fonctionnement de cet équipement, ou encore si vous avez besoin de renseignements supplémentaires, n'hésitez pas à nous téléphoner au 770-844-4200.

Cette publication s'appuie sur l'information qui était disponible au moment de l'impression. À la société AutomationDirect, nous nous efforçons constamment d'améliorer nos produits et services. C'est pourquoi nous nous réservons le droit d'apporter des modifications aux produits ou aux publications en tout temps, sans préavis ni quelque obligation que ce soit. La présente publication peut aussi porter sur des caractéristiques susceptibles de ne pas être offertes dans certaines versions révisées du produit.

Marques de commerce

La présente publication peut contenir des références à des produits fabriqués ou offerts par d'autres entreprises. Les désignations des produits et des entreprises peuvent être des marques de commerce et appartiennent exclusivement à leurs propriétaires respectifs. AutomationDirect nie tout intérêt dans les autres marques et désignations.

**Copyright 2004, 2007, 2008, 2009, Automationdirect.com® Incorporated
Tous droits réservés**

Nulle partie de ce manuel ne doit être copiée, reproduite ou transmise de quelque façon que ce soit sans le consentement préalable écrit de la société Automationdirect.com® Incorporated. AutomationDirect conserve les droits exclusifs à l'égard de tous les renseignements contenus dans le présent document.

⚡ WARNING ⚡



WARNING: Read this manual thoroughly before using *SureStep*[™] Stepping System drives, motors, and power supplies.



WARNING: AC input power must be disconnected before performing any maintenance. Do not connect or disconnect wires or connectors while power is applied to the circuit. Maintenance must be performed only by a qualified technician.



WARNING: There are highly sensitive MOS components on the printed circuit boards, and these components are highly sensitive to static electricity. To avoid damage to these components, do not touch the components or the circuit boards with metal objects or with your bare hands.



WARNING: Ground the *SureStep*[™] power supply using the ground terminal. The grounding method must comply with the laws of the country where the equipment is to be installed. Refer to “Power Supply Terminal & Component Layout” in the Power Supply chapter.

THIS PAGE
INTENTIONALLY
LEFT BLANK

SURESTEP™

Stepping Systems

USER MANUAL

Please include the Manual Number and the Manual Issue, both shown below, when communicating with Technical Support regarding this publication.

Manual Number: **STP-SYS-M-WO**

Issue: **Second Edition, Revision A**

Issue Date: **06/2009**

Publication History		
Issue	Date	Description of Changes
First Edition	7/28/04	Original
1st Ed, Rev A	8/26/04	AC power fuse changed from 2A slow blow to 3A fast acting, plus other minor changes and corrections.
1st Ed, Rev B	3/28/07	Added wiring diagrams for both sink and source for indexers and PLCs with 12-24 VDC outputs. Also corrected value for r^4 from 64 to 1296 in formula under Step 4 on page 15 of Appendix A.
Second Edition	11/2008	Changed name of user manual (was STP-SYS-M). Added new components: 3 new power supplies: STP-PWR-4805, -4810, -7005 2 new drives: STP-DRV-4850, -80100 5 new motors: STP-MTR-17040, STP-MTRH-23079, -34066, -34097, -34127 2 new cables: STP-EXTH-020, STP-232RJ11-CBL Other minor changes throughout.
2nd Ed, Rev A	06/2009	Advanced drives RS-232 communication port pin-out; pages 3-4 & B-7

THIS PAGE
INTENTIONALLY
LEFT BLANK

TABLE OF CONTENTS



Chapter 1: Getting Started	1-1
Manual Overview	1-2
<i>SureStep</i> [™] System Introduction	1-3
Microstepping Drives Introduction	1-4
Bipolar Step Motor Introduction	1-6
Stepping System Power Supply Introduction	1-7
Selecting the Stepping System	1-8
Use with <i>Direct</i> LOGIC PLCs	1-8
Chapter 2: <i>SureStep</i> [™] STP-DRV-4035 Microstepping Drive	2-1
Features	2-2
Block Diagram	2-2
Specifications	2-3
Typical Wiring Diagram	2-4
Connection and Adjustment Locations	2-4
The Enable Input	2-9
Setting Phase Current	2-10
Microstepping	2-12
Idle Current Reduction	2-13
Self Test	2-13
Choosing a Power Supply	2-14
Mounting the Drive	2-15
Dimensions	2-16

Chapter 3: *SureStep*[™] Advanced Microstepping Drives . . .3-1

- Features3-2
- Specifications3-3
- Typical Wiring Diagram3-4
- Connection Locations & Pin-out3-4
- Connecting the Motor3-5
- Connecting the Power Supply3-6
- Connecting the I/O3-7
- Drive Configuration3-11
- SureStep* Pro Software3-13
- Choosing a Power Supply3-16
- Mounting the Drive3-17
- Dimensions and Mounting Slot Locations3-17

Chapter 4: *SureStep*[™] Stepping Motors4-1

- Features4-2
- Design and Installation Tips4-2
- Specifications4-3
- Power Supply and Step Motor Drive4-4
- Mounting the Motor4-4
- Connecting the Motor4-4
- Motor Dimensions and Cabling4-5
- Torque vs. Speed Charts4-7

Chapter 5: *SureStep*[™] Stepping System Power Supplies .5-1

- Features5-2
- Specifications5-3
- Power Supply Terminal & Component Layout5-4
- Mounting the Power Supply5-5
- Dimensions5-6

Appendix A: Selecting the <i>SureStep</i> [™] Stepping System . . .	A-1
Selecting the <i>SureStep</i> [™] Stepping System	A-2
Leadscrew - Example Calculations	A-8
Belt Drive - Example Calculations	A-11
Index Table - Example Calculations	A-14
Engineering Unit Conversion Tables, Formulae, & Definitions:	A-17
 Appendix B: Using <i>SureStep</i> [™] with <i>Direct</i> LOGIC PLCs . . .	B-1
Compatible <i>Direct</i> LOGIC PLCs and Modules	B-2
Typical Connections to a DL05 PLC	B-4
Typical Connections to an H0-CTRIO	B-5
Typical Connections – Multiple Drive/Motors	B-6
Typical PLC Serial Connections to an Advanced <i>SureStep</i> Drive	B-7

THIS PAGE
INTENTIONALLY
LEFT BLANK

GETTING STARTED



In This Chapter...

Manual Overview	1-2
Overview of this Publication	1-2
Who Should Read this Manual	1-2
Technical Support	1-2
Special Symbols	1-2
<i>SureStep</i> [™] System Introduction	1-3
<i>SureStep</i> [™] System Recommended Component Compatibility	1-3
<i>SureStep</i> [™] Part Number Explanation	1-3
Microstepping Drives Introduction	1-4
Standard Microstepping Drive	1-4
Advanced Microstepping Drive	1-5
Bipolar Step Motor Introduction	1-6
Stepping System Power Supply Introduction	1-7
Selecting the Stepping System	1-8
Use with <i>Direct</i> LOGIC PLCs	1-8

Manual Overview

Overview of this Publication

Thank you for selecting the *SureStep*™ Stepping System components. This user manual describes the selection, installation, configuration, and methods of operation of the *SureStep*™ Stepping System. We hope our dedication to performance, quality and economy will make your motion control project successful.

Who Should Read this Manual

This manual contains important information for those who will install, maintain, and/or operate any of the *SureStep*™ Stepping System devices.

Technical Support

By Telephone: 770-844-4200
(Mon.-Fri., 9:00 am – 6:00 pm E.T.)

On the Web: www.automationdirect.com

Our technical support group is glad to work with you in answering your questions. If you cannot find the solution to your particular application, or, if for any reason you need additional technical assistance, please call technical support at 770-844-4200. We are available weekdays from 9:00 am to 6:00 pm Eastern Time.

We also encourage you to visit our web site where you can find technical and non-technical information about our products and our company. Visit us at www.automationdirect.com.

Special Symbols



When you see the “notepad” icon in the left-hand margin, the paragraph to its immediate right will be a special note which presents information that may make your work quicker or more efficient.



When you see the “exclamation mark” icon in the left-hand margin, the paragraph to its immediate right will be a WARNING. This information could prevent injury, loss of property, or even death (in extreme cases).

SureStep™ System Introduction

SureStep open-loop stepping systems provide simple and accurate control of position and speed where lower power and cost are considerations. The SureStep family of stepping components includes power supplies, drives, motors, and cables. The **Direct**LOGIC family of PLCs or other indexers and motion controllers can be used to provide the signals that are "translated" by the microstepping drives into precise movement of the stepping motor shaft.

SureStep™ System Recommended Component Compatibility

SureStep™ System Recommended Component Compatibility				
Drives (1)	Power Supplies (1)		Motors & Extension Cables (2,3)	
STP-DRV-4035	-	-	STP-PWR-3204	STP-MTR-xxxxx & STP-EXT-020 STP-MTRH-xxxxx & STP-EXTH-020
STP-DRV-4850	-	STP-PWR-4805		
STP-DRV-80100	STP-PWR-7005	STP-PWR-4810		
<p>1) Caution: Do not use a power supply that exceeds the drive input voltage range. Using a lower voltage power supply with a higher voltage drive is acceptable, but will not provide full system performance.</p> <p>2) MTR motors have connectors compatible with the EXT extension cables.</p> <p>3) MTRH motors have connectors compatible with the EXTH extension cables.</p>				

SureStep™ Part Number Explanation

STP- M T R H - 23079

■ **Component Capacity**

For DRV: 2-digit max nominal voltage followed by max current with 1 implied decimal place
 4035: 40V, 3.5A
 4850: 48V, 5.0A
 80100: 80V, 10.0A

For EXT(H): cable length in feet
 For MTR(H): 2-digit NEMA frame size followed by approximate length in mm
 For PWR: 2-digit output voltage followed by output current

■ **Component Type**

DRV: stepper drive
 EXT: motor extension cable
 EXTH: high-power motor extension cable
 MTR: stepper motor
 MTRH: high-power stepper motor
 PWR: power supply

■ **SureStep Series Designation:** STP

Microstepping Drives Introduction

There are two different basic types of microstepping drives offered in the *SureStep*™ series. One DIP-switch configurable model with a pulse input is available, as well as two software configurable advanced models with multiple operating modes.

Standard Microstepping Drive

The *SureStep*™ STP-DRV-4035 standard microstepping drive uses pulse input signals, and is configured with DIP switches on the drive. To use this drive in a step motor control system, you will need the following:

- 12-42 volt DC power supply for the motor drive. The *SureStep* STP-PWR-3204 power supply from AutomationDirect is the best choice. If you decide not to use the STP-PWR-3204, please read the section entitled “Choosing a Power Supply” in the STP-DRV-4035 Drive chapter of this user manual.
- A source of step pulses. Signal may be sinking (NPN), sourcing (PNP), or differential.
- The step inputs can be CW/CCW, step and direction, or quadrature.
- A compatible step motor, such as an AutomationDirect *SureStep* STP-MTR(H)-xxxxx. (Motor extension cables STP-EXT(H)-020 are also available.)
- A small flat blade screwdriver for tightening the connectors.

The STP-DRV-4035 standard microstepping drive is an open frame design.



STP-DRV-4035

Refer to the “*SureStep* STP-DRV-4035 Microstepping Drive” chapter of this user manual for complete details on the installation, configuration, and wiring of this drive.

Advanced Microstepping Drive

The *SureStep*™ advanced microstepping drives (STP-DRV-4850 & -80100) are capable of accepting several different forms of input signals for control: pulse, analog, serial communication, or internal indexing. These drives are configured by computer with software which is included with the drive. To use one of these drives in a step motor control system, you will need the following:

- A DC power supply for the motor drive. A compatible *SureStep* STP-PWR-xxxx power supply from AutomationDirect is the best choice.
- A source of input control signals, such as a **Direct**Logic PLC from AutomationDirect.
- A compatible step motor, such as an AutomationDirect *SureStep* STP-MTR(H)-xxxxx. (Motor extension cables STP-EXT(H)-020 are also available.)
- A small flat blade screwdriver for tightening the connectors.

The *SureStep* advanced microstepping drives are enclosed with removable wiring terminal blocks.



STP-DRV-80100

Refer to the “*SureStep*™ Advanced Microstepping Drives” chapter of this user manual for complete details on the installation, configuration, and wiring of this drive.

Bipolar Step Motor Introduction

AutomationDirect offers nine different models of bipolar step motors with mounting flanges in NEMA frame sizes 17, 23, and 34. There are five High Torque (STP-MTR-xxxxx) motors available, as well as four Higher Torque (STP-MTRH-xxxxx) motors. All of the motors have a 12 inch connectorized pigtail cable, and optional matching 20 ft connectorized extension cables (STP-EXT(H)-020) are also available.

Refer to the “*SureStep™* Stepping Motors” chapter in this user manual for complete details on the specifications, installation, mounting, dimensions, and wiring of the *SureStep* step motors.



**STP-MTR(H)-xxxxx
NEMA 17, 23, 34
Frame Sizes**

Stepping System Power Supply Introduction

The *SureStep* stepping system power supplies are designed to work with *SureStep* microstepping drives and motors. The different power supply models can provide unregulated DC power at the applicable voltage and current levels for various *SureStep* drives and motors. The power supplies also provide a regulated 5VDC, 500 mA logic supply output for indexer and PLC logic outputs to control the *SureStep* drives.



The stepping system power supplies can supply power for multiple *SureStep* STP-DRV-xxxx microstepping motor drives, depending on step motor size and application requirements.

Refer to the Power Supply chapter of this user manual for complete details on the specifications, installation, mounting, dimensions, and wiring of the *SureStep* stepping system power supplies.

Selecting the Stepping System

Refer to Appendix A: Selecting the *SureStep*™ Stepping System for detailed information on how to calculate requirements for various applications using stepping motors for motion control.

Use with *Direct*LOGIC PLCs

Refer to Appendix B: Using *SureStep*™ with *Direct*LOGIC PLCs for detailed information on wiring the *SureStep* Stepping System components to *Direct*LOGIC PLCs and high-speed counter modules.

The following is a summary of the *Direct*LOGIC PLCs⁽¹⁾ and module part numbers that are suitable to work with the *SureStep* Stepping Systems:

D0-05AD

D0-05DD

D0-05DD-D

D0-06DD1

D0-06DD2

D0-06DD1-D

D0-06DD2-D

H0-CTRIO

F1-130AD

F1-130DD

F1-130DD-D

H2-CTRIO⁽²⁾

D2-CTRINT

T1H-CTRIO⁽²⁾

H4-CTRIO

(1) Any *Direct*LOGIC PLC capable of RS-232 ASCII communication can write serial commands to the *SureStep Advanced* Microstepping Drives (STP-DRV-4850 & -80100). These PLCs include DL 05, 06, 250-1, 260, 350, & 450. However, we strongly recommend using DL06 or DL260 PLCs for serial commands due to their more advanced ASCII instruction set which includes PRINTV and VPRINT commands.

(2) The H2-CTRIO and T1H-CTRIO High Speed Counter I/O Interface Modules can also be used to control the *SureStep* Stepping System in PC-Based Control systems with Think & Do/Studio, or with our embedded WinPLC/EBC module plugged into the CPU slot of the DL205 base.

SURESTEP™
STP-DRV-4035
MICROSTEPPING DRIVE



In This Chapter...

Features	2-2
Block Diagram	2-2
Specifications	2-3
Typical Wiring Diagram	2-4
Connection and Adjustment Locations	2-4
Connecting the Motor	2-5
Connecting the Power Supply	2-6
Connecting the Logic	2-7
Using Logic That is Not 5 volt TTL Level	2-9
The Enable Input	2-9
Setting Phase Current	2-10
Current Setting Formula	2-10
Current Setting Table	2-11
Microstepping	2-12
Idle Current Reduction	2-13
Self Test	2-13
Choosing a Power Supply	2-14
Mounting the Drive	2-15
Dimensions	2-16

Features

- Drives sizes 17 through 34 step motors
- Pulse width modulation, MOSFET 3 state switching amplifiers
- Phase current from 0.4 to 3.5 amps (switch selectable, 32 settings)
- Optically isolated step, direction and enable inputs
- Half, 1/5, 1/10, 1/50 step (switch selectable)
- Automatic 50% idle current reduction (can be switched off)



Block Diagram

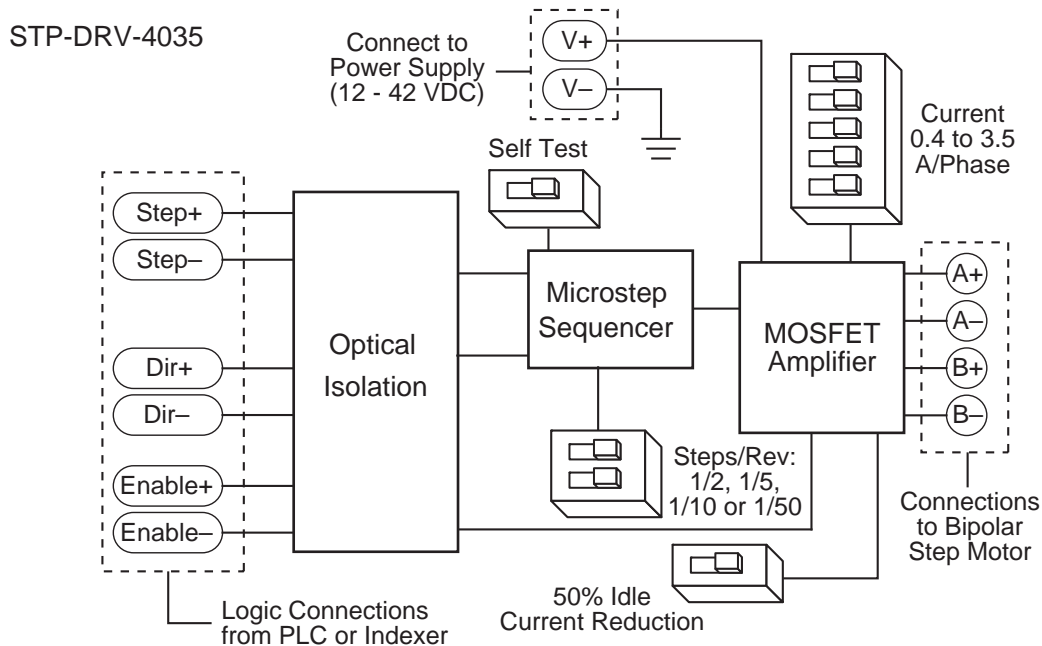

Specifications

SureStep™ Microstepping Drives Specifications		
Part Number	STP-DRV-4035	
Input Power (with red Power On LED)	12-42 VDC (including ripple voltage)	
Output Power	Output current selectable from 0.4 to 3.5 Amps/phase motor current (maximum output power is 140 W)	
Current Controller	Dual H-bridge Bipolar Chopper (3-state 20 kHz PWM with MOSFET switches)	
Input Signals	Input Signal Circuit	Opto-coupler input with 440 Ohm resistance (5 to 15 mA input current), Logic Low is input pulled to 0.8 VDC or less, Logic High is input 4 VDC or higher
	Pulse Signal	Motor steps on falling edge of pulse and minimum pulse width is 0.5 microseconds
	Direction Signal	Needs to change at least 2 microseconds before a step pulse is sent
	Enable Signal	Logic 1 will disable current to the motor (current is enabled with no hook-up or logic 0)
DIP Switch Selectable Functions	Self Test	Off or On (uses half-step to rotate 1/2 revolution in each direction at 100 steps/second)
	Microstepping	400 (200x2), 1,000 (200x5), 2,000 (200x10), or 10,000 (200x50) steps/rev
	Idle Current Reduction	0% or 50% reduction (idle current setting is active if motor is at rest for 1 second or more)
	Phase Current Setting	0.4 to 3.5 Amps/phase with 32 selectable levels
Drive Cooling Method	Natural convection (mount drive to metal surface if possible)	
Dimensions	3 x 4 x 1.5 inches [76.2 x 101.6 x 38.1 mm]	
Mounting	Use #4 screws to mount on wide side (4 screws) or narrow side (2 screws)	
Connectors	Screw terminal blocks with AWG 18 maximum wire size	
Weight	9.3 oz. [264g]	
Chassis Operating Temperature	0–55 °C [32–131 °F] recommended; 70 °C [158 °F] maximum (use fan cooling if necessary); 90% non-condensing maximum humidity	
Agency Approvals	CE (complies with EN55011A and EN50082-1 (1992))	



*Note: The STP-DRV-4035 Microstepping Drive works with 4, 6 and 8 lead bipolar step motors. All **AUTOMATIONDIRECT** SureStep™ motors are four lead bipolar step motors.*

Typical Wiring Diagram

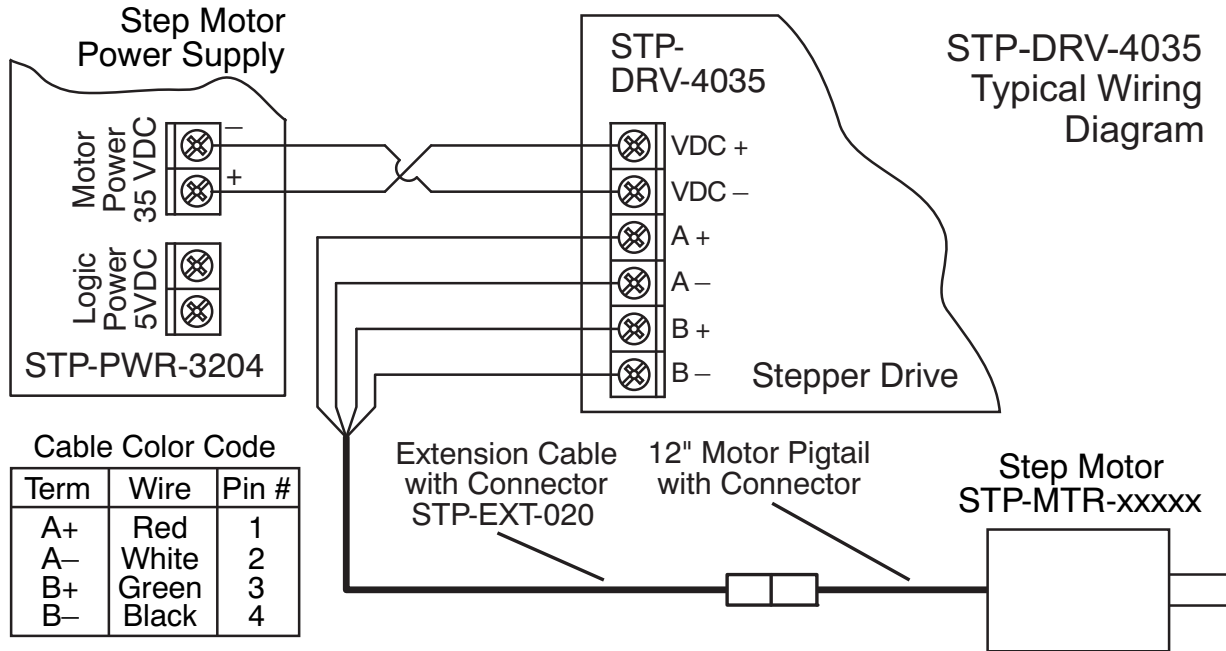

Connection and Adjustment Locations

The sketch below shows where to find the important connection and adjustment points.

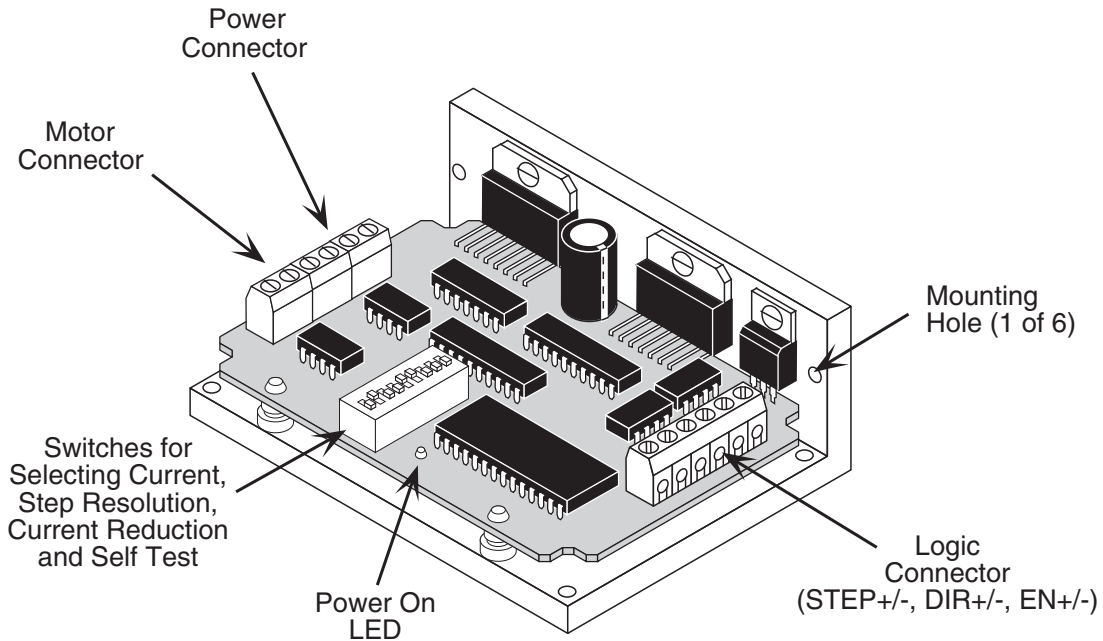

Connecting the Motor



WARNING: When connecting a step motor to the SureStep™ STP-DRV-4035 microstepping drive, be sure that the motor power supply is switched off. When using a motor not supplied by AUTOMATIONDIRECT, secure any unused motor leads so that they can't short out to anything. Never disconnect the motor while the drive is powered up. Never connect motor leads to ground or to a power supply. (See the Typical Wiring Diagram shown on page 2-4 of this chapter for the step motor lead color code of AUTOMATIONDIRECT supplied motors.)

You must now decide how to connect your stepping motor to the SureStep™ STP-DRV-4035 microstepping drive.

Four lead motors

Four lead motors can only be connected one way. Please follow the wiring diagram shown to the right.

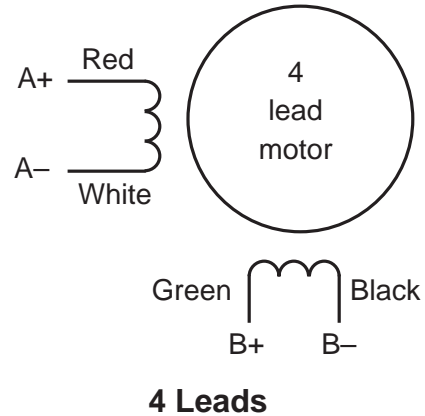

Note: All AUTOMATIONDIRECT SureStep™ motors are four lead bipolar step motors.

Six lead motors

Six lead motors can be connected in series or center tap. In series mode, motors produce more torque at low speeds, but cannot run as fast as in the center tap configuration. In series operation, the motor should be operated at 30% less than rated current to prevent overheating. Wiring diagrams for both connection methods are shown below. **NC** means not connected to anything.

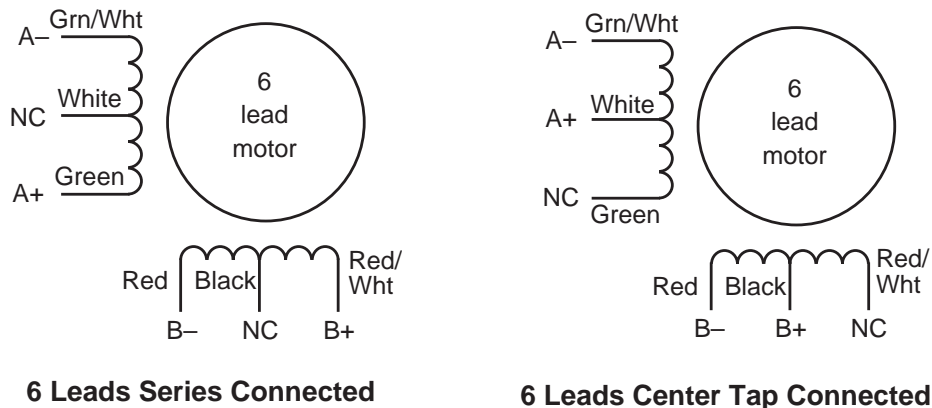

Note: Be aware that step motor wire lead colors vary from one manufacturer to another.

Eight lead motors

Eight lead motors can also be connected in two ways: series or parallel. Series operation gives you more torque at low speeds and less torque at high speeds. When using series connection, the motor should be operated at 30% less than the rated current to prevent over heating. Parallel operation allows a greater torque at high speed. When using parallel connection, the current can be increased by 30% above rated current. Care should be taken in either case to assure the motor is not being overheated. The wiring diagrams for eight lead motors are shown below.

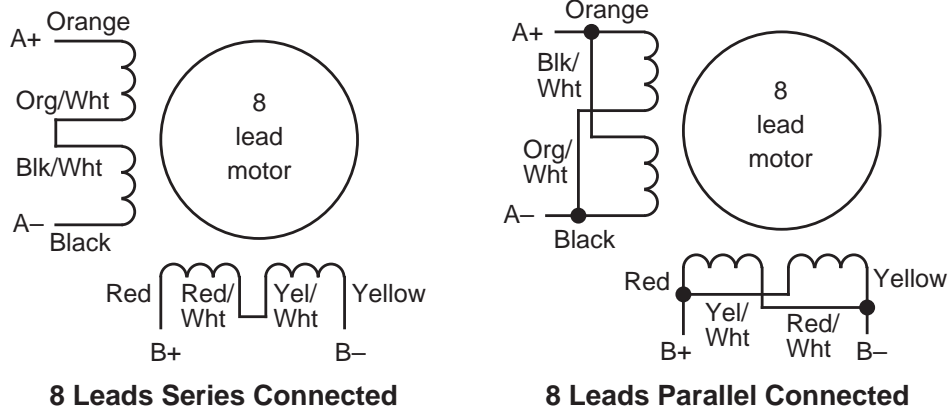

Note: Be aware that step motor wire lead colors vary from one manufacturer to another.

Connecting the Power Supply

The STP-PWR-3204 power supply from **AUTOMATIONDIRECT** is the best choice to power the step motor drive. If you need information about choosing a different power supply, please read the section titled "Choosing a Power Supply" in this manual.

If your power supply does not have a fuse on the output or some kind of short circuit current limiting feature you need to put a 4 amp fast acting fuse between the drive and power supply. Install the fuse on the + power supply lead.

Connect the motor power supply "+" terminal to the driver terminal labeled "+ VDC". Connect power supply "-" to the drive terminal labeled "VDC-". Use no smaller than 18 gauge wire. **Be careful not to reverse the wires.** Reverse connection will destroy your drive and void the warranty.

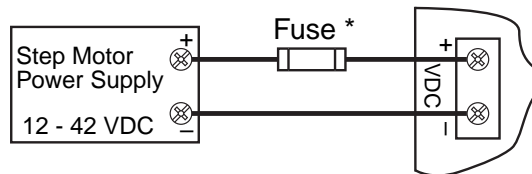

* External fuse not req'd when using an STP-PWR-3204 P/S; fuse is internal.



Do NOT use STP-PWR-48xx or -70xx power supplies with an STP-DRV-4035 drive, because those power supplies exceed the voltage limit of this drive.

Connecting the Logic

The *SureStep* drive contains optical isolation circuitry to prevent the electrical noise inherent in switching amplifiers from interfering with your circuits. Optical isolation is accomplished by powering the motor driver from a different supply source than your control circuits. There is no electrical connection between the two; signal communication is achieved by infrared light. When your circuit turns on or turns off, an infrared LED (built into the drive), signals a logic state to the phototransistors that are wired to the brains of the drive. A schematic diagram input circuit is shown to the right.

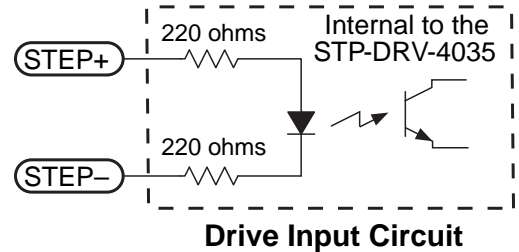

You will need to supply a source of step pulses to the drive at the STEP+ and STEP- terminals and a direction signal at the DIR+ and DIR- terminals, if bidirectional rotation is required. You will also need to determine if the **ENABLE** input terminals will be used in your application. Operation, voltage levels and wiring on the **ENABLE** terminals is the same as the **STEP** and **DIRECTION** terminals. The EN+ and EN- terminal can be left not connected if the enable function is not required.

All logic inputs can be controlled by a DC output signal that is either sinking (NPN), sourcing (PNP), or differential.

On the next couple of pages are examples for connecting various forms of outputs from both indexers and PLCs.

Connecting to an Indexer with Sinking Outputs

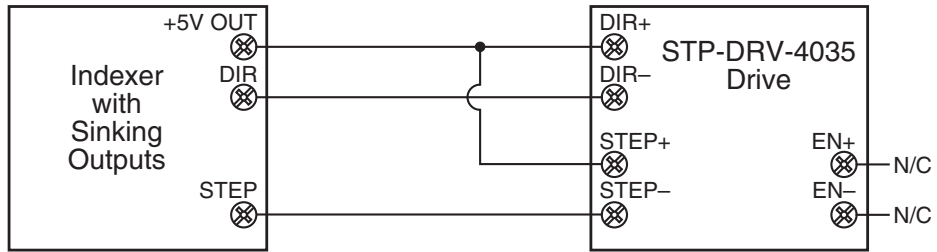

Connecting to an Indexer with Sourcing Outputs

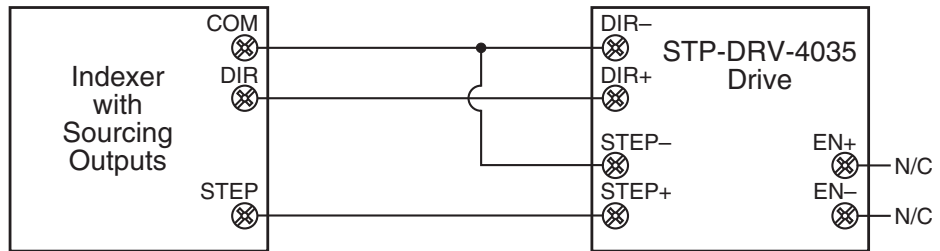

Connecting to an Indexer with Differential Outputs

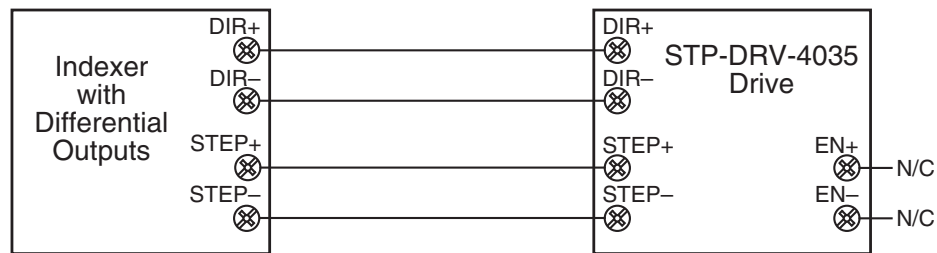

Note: Many high speed indexers have differential outputs.

Using Logic That is Not 5 volt TTL Level

Some step and direction signals, especially those of PLCs, don't use 5 volt logic. You can connect signal levels as high as 24 volts to the *SureStep* drive if you add external dropping resistors to the STEP, DIR and EN inputs, as shown below.

- For 12 volt logic, add 820 ohm, 1/4 watt resistors
- For 24 volt logic, use 2200 ohm, 1/4 watt resistors

Connecting to an Indexer with Sink or Source 12-24 VDC Outputs

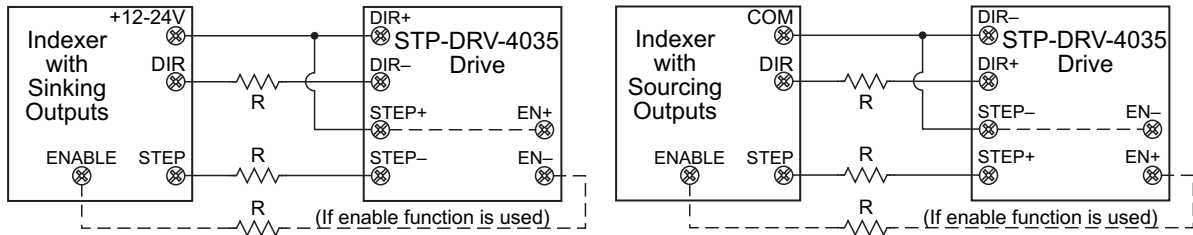

Connecting to a PLC with Sink or Source 12-24 VDC Outputs

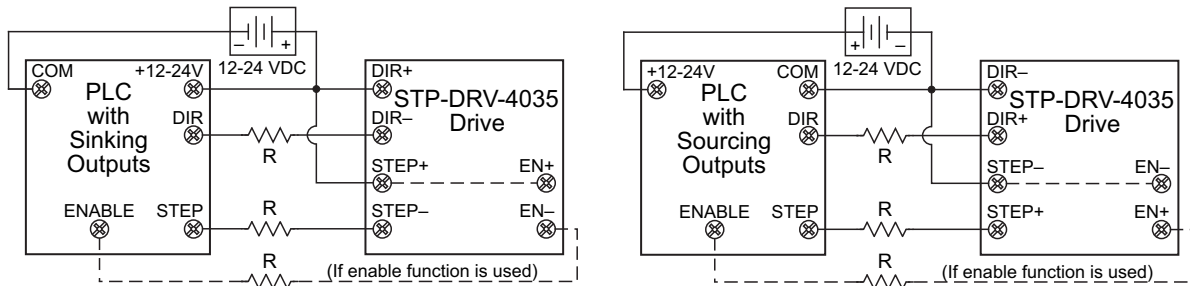

Note: Most PLCs can use 24 VDC Logic.

The Enable Input

The **ENABLE** input allows the user to turn off the current to the motor by providing a positive voltage between EN+ and EN-. The logic circuitry continues to operate, so the drive "remembers" the step position even when the amplifiers are disabled. However, the motor may move slightly when the current is removed depending on the exact motor and load characteristics.



*Note: If you have no need to disable the amplifiers, you don't need to connect anything to the **ENABLE** input.*

**Step Table
(half stepping)**

Step	A+	A-	B+	B-
0	open	open	+	-
1	+	-	+	-
2	+	-	open	open
3	+	-	-	+
4	open	open	-	+
5	-	+	-	+
6	-	+	open	open
7	-	+	+	-
8	open	open	+	-

DIR=1
cw

DIR=0
ccw

Step 0 is the Power Up State

Setting Phase Current

Before you turn on the power supply the first time, you need to set the drive for the proper motor phase current. The rated current is usually printed on the motor label. The SureStep drive current is easy to set. If you wish, you can learn a simple formula for setting current and never need the manual again. Or you can skip to the table on the next page, find the current setting you want, and set the DIP switches according to the picture.

Current Setting Formula

Locate the bank of tiny switches near the motor connector. Five of the switches, DIP switch positions 5-9, have a value of current printed next to them, such as 0.1, 0.2, 0.4, 0.8 and 1.6. Each switch controls the amount of current, in amperes (A), that its label indicates in addition to the minimum current value of 0.4 Amps. **There is always a base current of 0.4 Amps, even with all five DIP switches set to the "off" position (away from their labels).** To add to that, slide the appropriate switches toward their labels on the PC board. You may need a small screwdriver for this.

**DIP switch current total settings =
step motor required phase current – 0.4 Amps always present base current**

Example





Suppose you want to set the drive for 2.2 Amps per phase based on the step motor showing a phase current of 2.2 Amps. You need the base current of 0.4 Amps plus another 1.6 and 0.2 Amps.

$$2.2 = 0.4 + 1.6 + 0.2$$

Slide the 1.6 and 0.2 Amp DIP switches toward the labels as shown in the figure to the right.

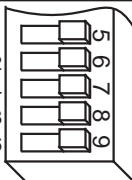
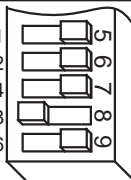
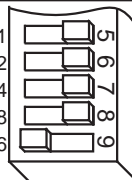
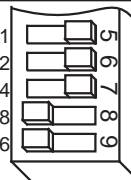
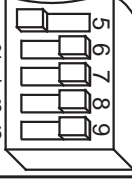
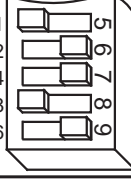
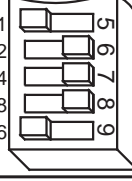
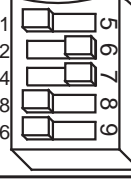
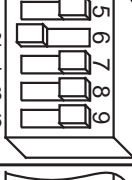
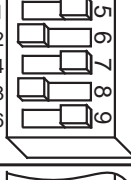
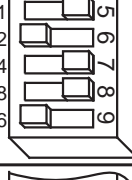
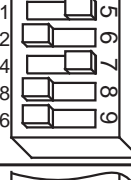
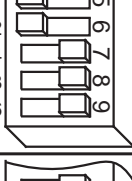
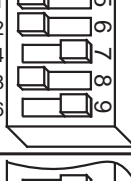
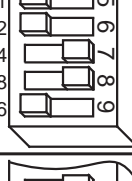
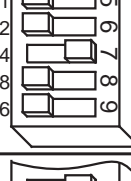
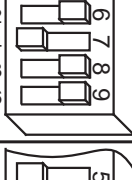
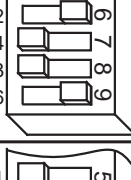
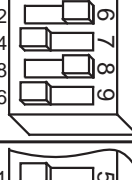
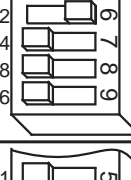

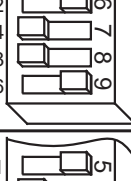
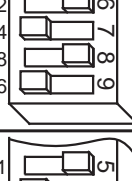
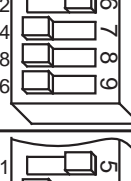
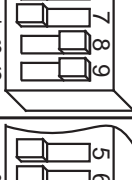
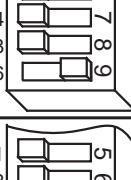
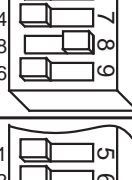
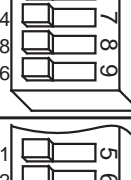
Current Setting Table

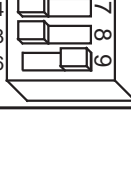
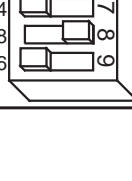
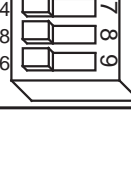
<p>0.4 0.1 0.2 AMPS/ PHASE 0.4 0.8 1.6</p> 	<p>1.2 0.1 0.2 AMPS/ PHASE 0.4 0.8 1.6</p> 	<p>2.0 0.1 0.2 AMPS/ PHASE 0.4 0.8 1.6</p> 	<p>2.8 0.1 0.2 AMPS/ PHASE 0.4 0.8 1.6</p> 	<p>Factory Default</p>
<p>0.5 0.1 0.2 AMPS/ PHASE 0.4 0.8 1.6</p> 	<p>1.3 0.1 0.2 AMPS/ PHASE 0.4 0.8 1.6</p> 	<p>2.1 0.1 0.2 AMPS/ PHASE 0.4 0.8 1.6</p> 	<p>2.9 0.1 0.2 AMPS/ PHASE 0.4 0.8 1.6</p> 	
<p>0.6 0.1 0.2 AMPS/ PHASE 0.4 0.8 1.6</p> 	<p>1.4 0.1 0.2 AMPS/ PHASE 0.4 0.8 1.6</p> 	<p>2.2 0.1 0.2 AMPS/ PHASE 0.4 0.8 1.6</p> 	<p>3.0 0.1 0.2 AMPS/ PHASE 0.4 0.8 1.6</p> 	
<p>0.7 0.1 0.2 AMPS/ PHASE 0.4 0.8 1.6</p> 	<p>1.5 0.1 0.2 AMPS/ PHASE 0.4 0.8 1.6</p> 	<p>2.3 0.1 0.2 AMPS/ PHASE 0.4 0.8 1.6</p> 	<p>3.1 0.1 0.2 AMPS/ PHASE 0.4 0.8 1.6</p> 	
<p>0.8 0.1 0.2 AMPS/ PHASE 0.4 0.8 1.6</p> 	<p>1.6 0.1 0.2 AMPS/ PHASE 0.4 0.8 1.6</p> 	<p>2.4 0.1 0.2 AMPS/ PHASE 0.4 0.8 1.6</p> 	<p>3.2 0.1 0.2 AMPS/ PHASE 0.4 0.8 1.6</p> 	
<p>0.9 0.1 0.2 AMPS/ PHASE 0.4 0.8 1.6</p> 	<p>1.7 0.1 0.2 AMPS/ PHASE 0.4 0.8 1.6</p> 	<p>2.5 0.1 0.2 AMPS/ PHASE 0.4 0.8 1.6</p> 	<p>3.3 0.1 0.2 AMPS/ PHASE 0.4 0.8 1.6</p> 	
<p>1.0 0.1 0.2 AMPS/ PHASE 0.4 0.8 1.6</p> 	<p>1.8 0.1 0.2 AMPS/ PHASE 0.4 0.8 1.6</p> 	<p>2.6 0.1 0.2 AMPS/ PHASE 0.4 0.8 1.6</p> 	<p>3.4 0.1 0.2 AMPS/ PHASE 0.4 0.8 1.6</p> 	
<p>1.1 0.1 0.2 AMPS/ PHASE 0.4 0.8 1.6</p> 	<p>1.9 0.1 0.2 AMPS/ PHASE 0.4 0.8 1.6</p> 	<p>2.7 0.1 0.2 AMPS/ PHASE 0.4 0.8 1.6</p> 	<p>3.5 0.1 0.2 AMPS/ PHASE 0.4 0.8 1.6</p> 	

Microstepping

Most step motor drives offer a choice between full step and half step resolutions. In most full step drives, both motor phases are used all the time. Half stepping divides each step into two smaller steps by alternating between both phases on and one phase on. Microstepping drives like the *SureStep* drive precisely control the amount of current in each phase at each step position as a means of electronically subdividing the steps even further. The *SureStep* drive offers a choice of half step and three microstep resolutions. The highest setting divides each full step into 50 microsteps, providing 10,000 steps per revolution when using a 1.8° motor.

In addition to providing precise positioning and smooth motion, microstep drives can be used to provide motion in convenient units. When the drive is set to 2,000 steps/rev (1/10 step) and used with a 5 pitch lead screw, you get .0001 inches/step.

Setting the step resolution is easy. Look at the dip switch on the *SureStep* drive. Next to switches 2 and 3, there are labels on the printed circuit board. Each switch has two markings on each end. Switch 2 is marked 1/5, 1/10 at one end and 1/5, 1/50 at the other. Switch 3 is labeled 1/2, 1/5 and 1/10, 1/50. To set the drive for a resolution, push both switches toward the proper label. For example, if you want 1/10 step, push switch 2 toward the 1/10 label (to the left) and push switch 3 toward 1/10 (on the right).

Please refer to the table below and set the switches for the resolution you want.

	<p>400 STEPS/REV (HALF)</p>	<p>2,000 STEPS/REV (1/10)</p>
Factory Default	<p>1,000 STEPS/REV (1/5)</p>	<p>10,000 STEPS/REV (1/50)</p>

Idle Current Reduction

Your drive is equipped with a feature that automatically reduces the motor current by 50% anytime the motor is not moving. This reduces drive heating by about 50% and lowers motor heating by 75%. This feature can be disabled if desired so that full current is maintained at all times. This is useful when a high holding torque is required. To minimize motor and drive heating we highly recommend that you enable the idle current reduction feature unless your application strictly forbids it.

Idle current reduction is enabled by sliding switch #4 toward the **50% IDLE** label, as shown in the sketch below. Sliding the switch away from the **50% IDLE** label disables the reduction feature.



**Idle Current Reduction
Selected
(Factory Default)**



No Current Reduction

Self Test

The SureStep drive includes a self test feature. This is used for trouble shooting. If you are unsure about the motor or signal connections to the drive, or if the SureStep drive isn't responding to your step pulses, you can turn on the self test.

To activate the self test, slide switch #1 toward the **TEST** label. The drive will slowly rotate the motor, 1/2 revolution forward, then 1/2 rev backward. The pattern repeats until you slide the switch away from the **TEST** label. The SureStep drive always uses half step mode during the self test, no matter how you set switches 2 and 3. The self test ignores the **STEP** and **DIRECTION** inputs while operating. The **ENABLE** input continues to function normally.



Self Test ON

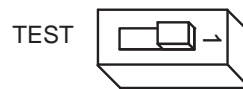

**Self Test OFF
(Factory Default)**

Choosing a Power Supply

Voltage

Chopper drives work by switching the voltage to the motor terminals on and off while monitoring current to achieve a precise level of phase current. To do this efficiently and silently, you'll want to have a power supply with a voltage rating at least five times that of the motor. Depending on how fast you want to run the motor, you may need even more voltage. More is better, the only upper limit being the maximum voltage rating of the drive itself: 42 volts (including ripple).

If you choose an unregulated power supply, do not exceed 30 volts DC. This is because unregulated supplies are rated at full load current. At lesser loads, like when the motor is not moving, the actual voltage can be up to 1.4 times the voltage list on the power supply label. The STP-PWR-3204 power supply is designed to provide maximum voltage, approximately 32 VDC, while under load without exceeding the upper limit of 42 VDC when unloaded.

Current

The maximum supply current you will need is the sum of the two phase currents. However, you will generally need a lot less than that, depending on the motor type, voltage, speed and load conditions. That's because the SureStep drive uses switching amplifiers, converting a high voltage and low current into lower voltage and higher current. The more the power supply voltage exceeds the motor voltage, the less current you'll need from the power supply.

We recommend the following selection procedure:

1. If you plan to use only a few drives, get a power supply with at least twice the rated phase current of the motor.
2. If you are designing for mass production and must minimize cost, get one power supply with more than twice the rated current of the motor. Install the motor in the application and monitor the current coming out of the power supply and into the drive at various motor loads. This will tell you how much current you really need so you can design in a lower cost power supply.

If you plan to use a regulated power supply you may encounter a problem with current foldback. When you first power up your drive, the full current of both motor phases will be drawn for a few milliseconds while the stator field is being established. After that the amplifiers start chopping and much less current is drawn from the power supply. If your power supply thinks this initial surge is a short circuit it may "foldback" to a lower voltage. With many foldback schemes the voltage returns to normal only after the first motor step and is fine thereafter. In that sense, unregulated power supplies are better. They are also less expensive.



The SureStep™ STP-PWR-3204 power supply from AutomationDirect is the best choice of DC power supply to use with the SureStep™ STP-DRV-4035 microstepping drive.

Mounting the Drive

You can mount your drive on the wide or the narrow side of the chassis. If you mount the drive on the wide side, use #4 screws through the four corner holes. For narrow side mounting applications, you can use #4 screws in the two side holes.

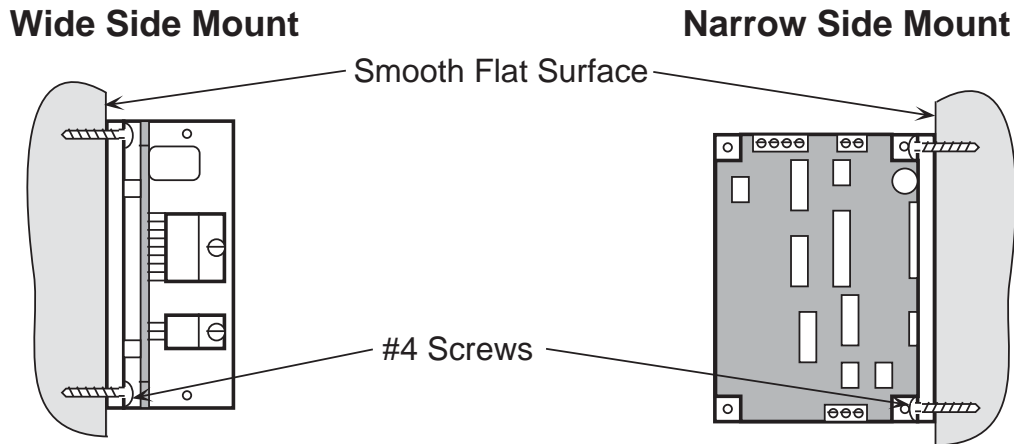

Unless you are running at 1 Amp/phase motor current or below, you may need a heat sink. Often, the metal subpanel being used for the control system will make an effective heat sink.

The amplifiers in the drive generate heat. Unless you are running at 1 amp or below, you may need a heat sink. To operate the drive continuously at maximum power you must properly mount it on a heat sinking surface with a thermal constant of no more than 4°C/Watt. Often, the metal enclosure of your system will make an effective heat sink.

Never use your drive in a space where there is no air flow or where other devices cause the surrounding air to be more than 70 °C. Never put the drive where it can get wet or where metal particles can get on it.

Dimensions

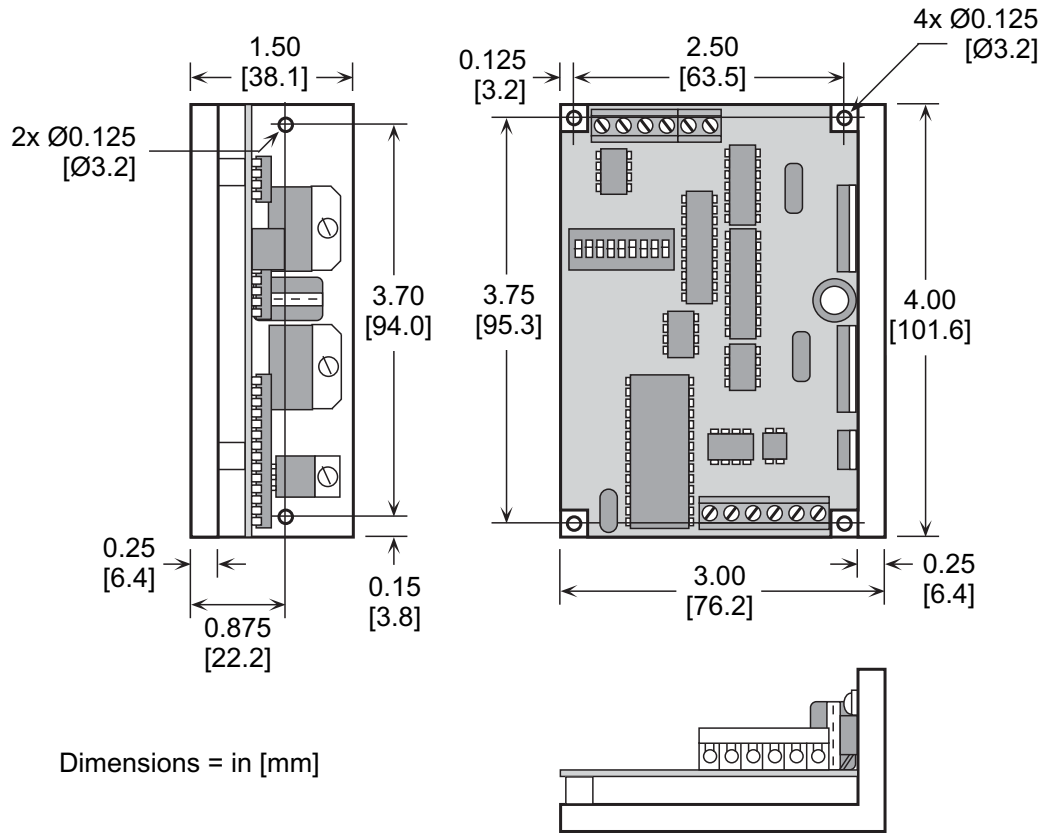

SURESTEP™
ADVANCED
MICROSTEPPING DRIVES



CHAPTER
3

In This Chapter...

Features	3-2
Specifications	3-3
Typical Wiring Diagram	3-4
Connection Locations & Pin-out	3-4
Connecting the Motor	3-5
Connecting the Power Supply	3-6
Connecting the I/O	3-7
<i>SureStep™</i> Drive Digital Inputs	3-7
Connecting STEP and DIR to 5V TTL Logic	3-7
Connecting STEP and DIR to Logic Other Than 5V TTL Level	3-8
Connections to the EN Input	3-9
Connecting the Analog Input	3-10
Connecting the Digital Output	3-10
Drive Configuration	3-11
<i>SureStep™</i> Pro Software	3-13
Choosing a Power Supply	3-16
Mounting the Drive	3-17
Dimensions and Mounting Slot Locations	3-17

Features

- Max 5A, 48V and max 10A, 80V models available
- Software configurable
- Programmable microsteps
- Internal indexer (via ASCII commands)
- Self test feature
- Idle current reduction
- Anti-resonance
- Torque ripple smoothing
- Step, analog, & serial communication inputs



Specifications

SureStep™ Series Specifications – Microstepping Drives		
Microstepping Drive	STP-DRV-4850 STP-DRV-80100	
Drive Type	Advanced microstepping drive with pulse or analog input, serial communication, & indexing capability	
Output Current	0.1-5.0 A/phase (in 0.01A increments) 0.1-10.0 A/phase (in 0.01A increments)	
Input Voltage (external p/s required)	24-48 VDC (nominal) (range: 18-53 VDC) 24-80 VDC (nominal) (range: 18-88 VDC)	
Configuration Method	SureStep Pro software (included)	
Amplifier Type	MOSFET, dual H-bridge, 4-quadrant	
Current Control	4-state PWM @ 20 kHz	
Protection	over-voltage, under-voltage, over-temperature, external output faults (phase-to-phase & phase-to-ground), inter-amplifier shorts	
Recommended Input Fusing	Fuse: 4A 3AG delay (ADC #MDL4) Fuse Holder: ADC #DN-F6L110 Fuse: 6.25A 3AG delay (ADC #MDL6-25) Fuse Holder: ADC #DN-F6L110	
Input Signals	Input Circuit	Opto-coupler input with 5 to 15 mA input current; Logic Low is input pulled to 0.8 VDC or less; Logic High is input 4 VDC or higher.
	Step/Pulse	optically isolated, differential, 5V, 330Ω; min pulse width = 250 ns max pulse frequency = 2MHz
	Direction	adjustable bandwidth digital noise rejection feature FUNCTIONS: step & direction, CW/CCW step, A/B quadrature, run/stop & direction, jog CW/CCW, CW/CCW limits
	Enable	optically isolated, 5-12V, 680Ω; FUNCTIONS: motor enable, alarm reset, speed select (oscillator mode)
	Analog	Range: 0-5 VDC; Resolution: 12 bit; FUNCTION: speed control
Output Signal	optically isolated, 24V, 10 mA max; FUNCTIONS: fault, motion, tach	
Communication Interface	RS-232; RJ11 (6P4C) receptacle	
Non-volatile Memory Storage	Configurations are saved in FLASH memory on-board the DSP.	
Features	Idle Current Reduction	reduction range of 0-90% of running current after delay selectable in ms
	Microstep Resolution	software selectable from 200 to 51200 steps/rev in increments of 2 steps/rev
	Modes of Operation	pulse (step) & direction, CW/CCW, A/B quadrature, velocity (oscillator), SCL serial commands
	Phase Current Setting	0.1-5.0 A/phase (in 0.01A increments) 0.1-10.0 A/phase (in 0.01A increments)
	Self Test	checks internal & external power supply voltages, diagnoses open motor phases
	Additional Features	Anti-resonance (Electronic Damping) Auto setup Serial Command Language (SCL) Host Control Step Smoothing Filter (Command Signal Smoothing & Microstep Emulation) Waveform (Torque Ripple) Smoothing
Connectors	Communication: RJ11 (6P4C); Other: removable screw terminal blocks	
Maximum Humidity	90% non-condensing	
Operating Temperature	0-55 °C [32-158 °F] (mount to suitable heat sink)	
Drive Cooling Method	natural convection (mount to suitable heat sink)	
Mounting	#6 mounting screws (mount to suitable heat sink)	
Dimensions	3.0 x 3.65 x 1.125 inches [76.2 x 92.7 x 28.6 mm]	
Weight	8 oz [227g] (approximate)	
Agency Approvals	CE, RoHS	

Typical Wiring Diagram

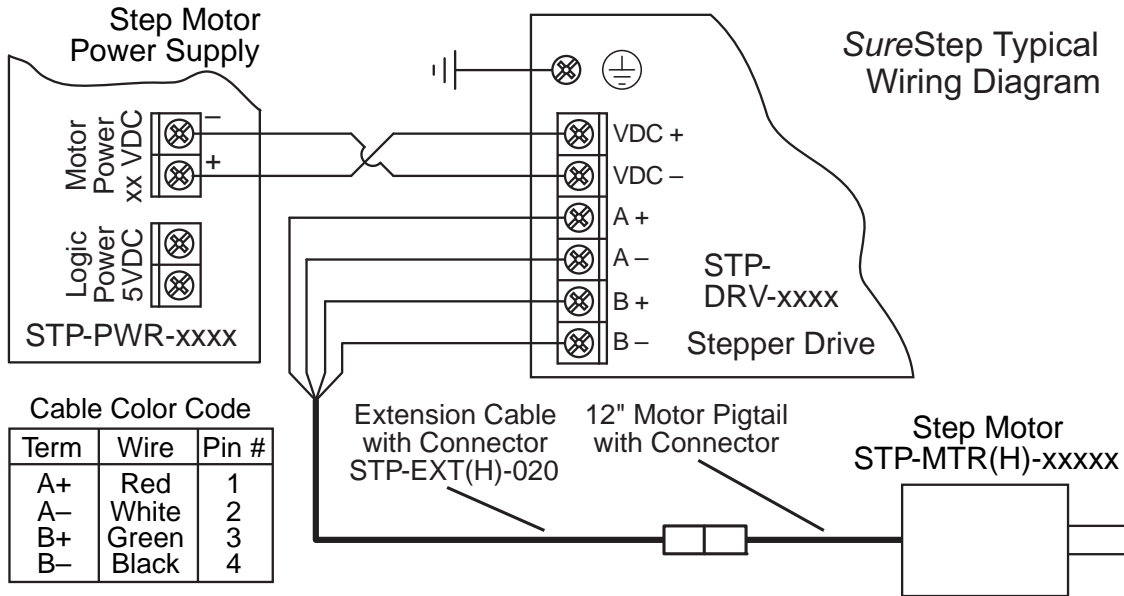

Connection Locations & Pin-out

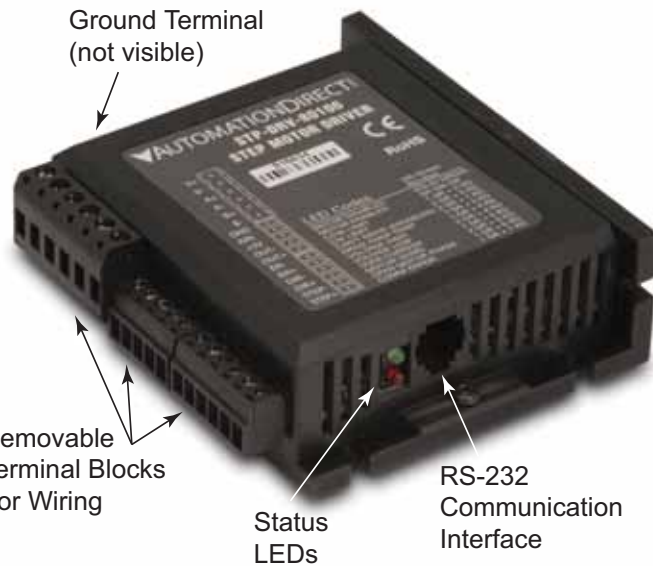
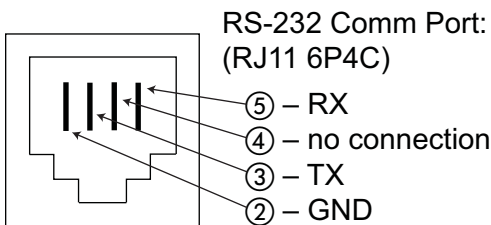
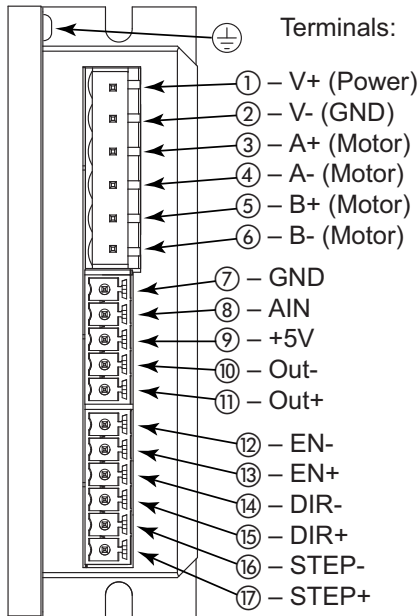

External wiring is connected using three separate pluggable screw terminal connectors. The power connections share a six position connector, the digital inputs share another six position connector, and the analog input and digital output share a five position connector.

Connecting the Motor



Warning: When connecting a step motor to a SureStep™ advanced microstepping drive, be sure that the motor power supply is switched off. When using a motor not supplied by AutomationDirect, secure any unused motor leads so that they can't short out to anything. Never disconnect the motor while the drive is powered up. Never connect motor leads to ground or to a power supply. (See the Typical Wiring Diagram shown in this chapter for the step motor lead color code of AutomationDirect supplied motors.)

Four lead motors

Four lead motors can only be connected one way, as shown below.

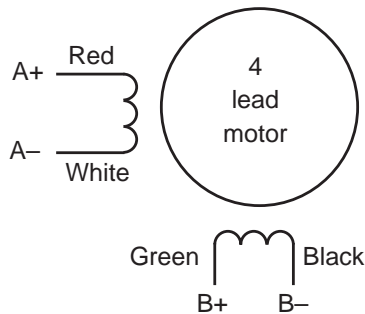

4 Leads



All AutomationDirect SureStep™ motors are four lead bipolar step motors.

Six lead motors

Six lead motors can be connected in series or center tap. Motors produce more torque at low speeds in series configuration, but cannot run as fast as in the center tap configuration. In series operation, the motor should be operated at 30% less than rated current to prevent overheating.

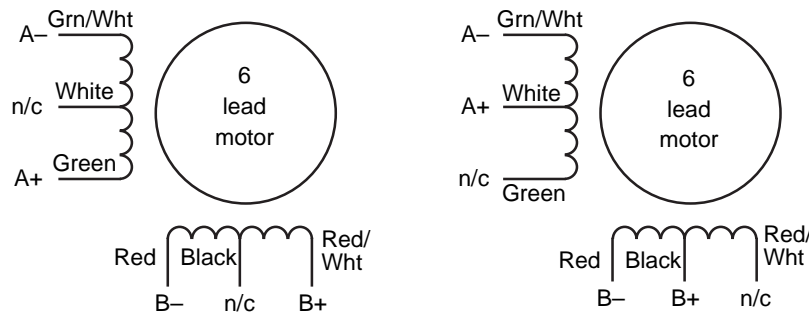

6 Leads Series Connected

6 Leads Center Tap Connected



Step motor wire lead colors vary from one manufacturer to another.

Eight lead motors

Eight lead motors can also be connected in two ways: series or parallel. Series operation gives you more torque at low speeds, but less torque at high speeds. When using series connection, the motor should be operated at 30% less than the rated current to prevent over heating. Parallel operation allows greater torque at high speeds. When using parallel connection, the current can be increased by 30% above rated current. Care should be taken in either case to assure the motor does not being overheat.

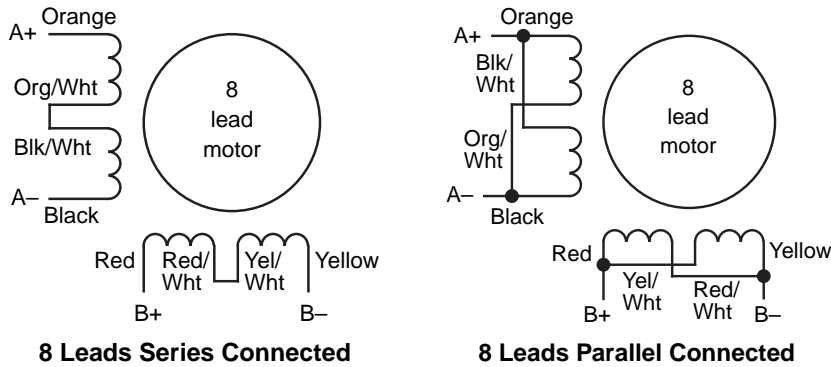

Step motor wire lead colors vary from one manufacturer to another.

Connecting the Power Supply

An STP-PWR-xxxx power supply from AutomationDirect is the best choice to power the step motor drive. If you need information about choosing a different power supply, refer to the section entitled "Choosing a Power Supply" in this chapter.

If your power supply does not have a fuse on the output or some kind of short circuit current limiting feature, you need a fuse between the drive and the power supply. Install the fuse on the + power supply lead.

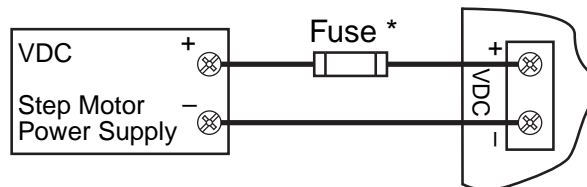

* External fuse not req'd when using an STP-PWR-xxxx P/S; fuse is internal.



Warning: Connect the motor power supply "+" terminal to the drive "+ VDC" terminal, and connect the power supply "-" terminal to the drive "VDC-" terminal. Use wire no smaller than 18 gauge, and be careful not to reverse the wires. Reverse connection will destroy your drive and void the warranty.

Connecting the I/O

SureStep™ Drive Digital Inputs

The SureStep advanced drives include two high speed 5V digital inputs (STEP and DIR), and one standard speed 5-12V input (EN).

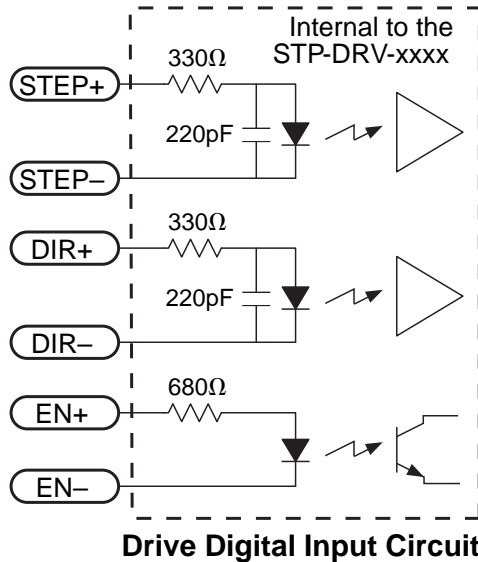

The digital inputs are optically isolated to reduce electrical noise problems. There is no electrical connection between the control and power circuits within the drive, and input signal communication between the two circuits is achieved by infrared light. Externally, the drive's motor power and control circuits should be supplied from separate sources, such as from a step motor power supply with separate power and logic outputs.

For bidirectional rotation, supply a source of step pulses to the drive at the STEP+ and STEP- terminals, and a directional signal at the DIR+ and DIR- terminals.

The ENABLE input allows the logic to turn off the current to the step motor by providing a signal to the EN+ and EN- terminals. The EN+ and EN- terminal can be left unconnected if the enable function is not required.

All logic inputs can be controlled by a DC output signal that is either sinking (NPN), sourcing (PNP), or differential.

Connecting STEP and DIR to 5V TTL Logic

Connecting to an Indexer with Sinking Outputs

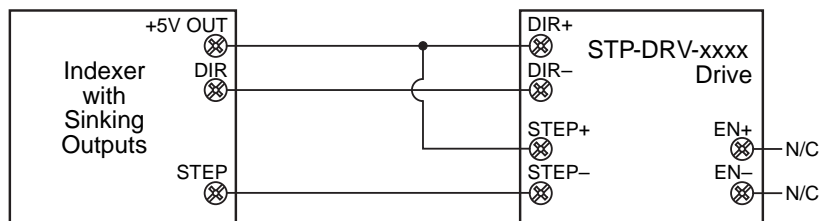

Connecting to an Indexer with Sourcing Outputs

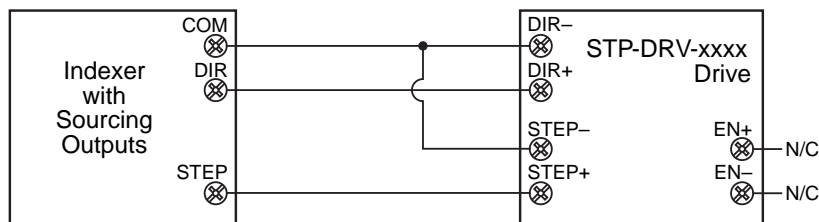

Connecting to an Indexer with Differential Outputs

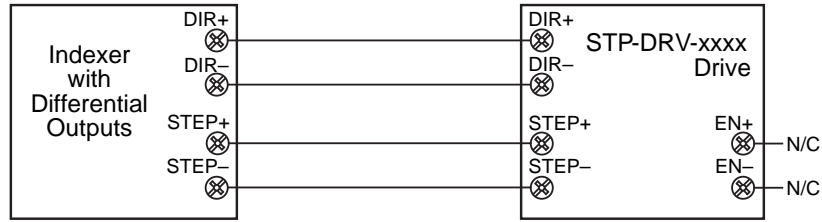

Many high speed indexers have differential outputs.

Connecting STEP and DIR to Logic Other Than 5V TTL Level

Some step and direction signals, especially those of PLCs, don't use 5 volt logic. You can connect signal levels as high as 24 volts to a SureStep advanced drive if you add external dropping resistors to the STEP, DIR and EN inputs.

- For 12V logic, use 820Ω, 1/4W resistors
- For 24V logic, use 2200Ω, 1/4W resistors



Most PLCs can use 24 VDC Logic.



Warning: 5VDC is the maximum voltage that can be applied directly to a high speed input (STEP and DIR). If using a higher voltage power source, install resistors to reduce the voltage at the inputs. Do NOT apply an AC voltage to an input terminal.

Connecting to an Indexer with Sink or Source 12-24 VDC Outputs

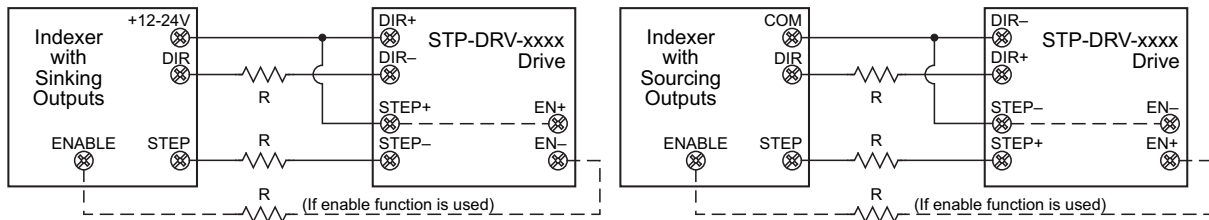

Connecting to a PLC with Sink or Source 12-24 VDC Outputs

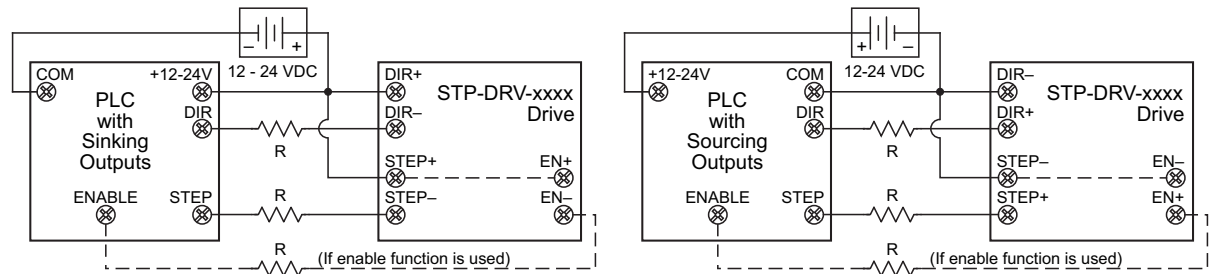

Connecting to Mechanical Switches at 24 VDC

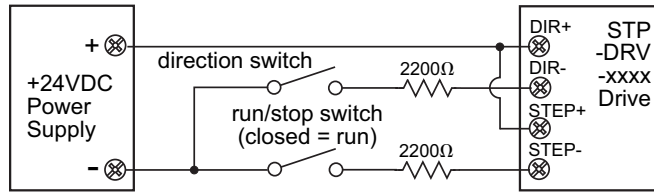

Connections to the EN Input

The ENABLE input allows the user to turn off the current to the motor by providing a 5-12 VDC positive voltage between EN+ and EN-. The logic circuitry continues to operate, so the drive "remembers" the step position even when the amplifiers are disabled. However, the motor may move slightly when the current is removed depending on the exact motor and load characteristics.



Warning: 12VDC is the maximum voltage that can be applied directly to the standard speed EN input. If using a higher voltage power source, install resistors to reduce the voltage at the input. Do NOT apply an AC voltage to an input terminal.

Connecting ENABLE Input to Relay or Switch

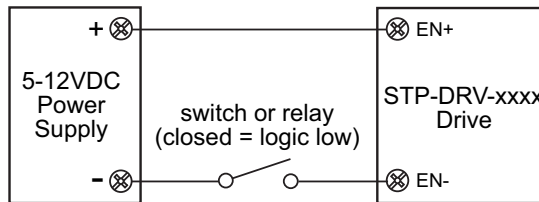

Connecting ENABLE Input to NPN Proximity Sensor

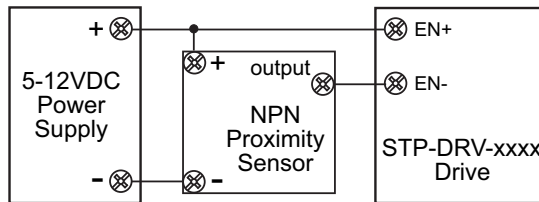

Connecting ENABLE Input to PNP Proximity Sensor

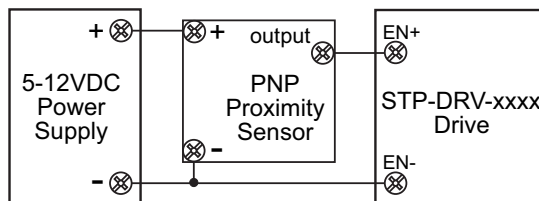

Leave the ENABLE input unconnected if you do not need to disable the amplifiers.

Connecting the Analog Input

The *SureStep* advanced drives have one 0-5 VDC analog input.

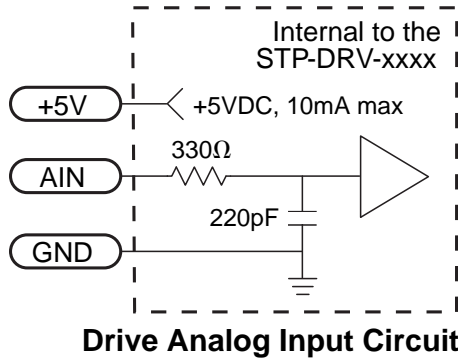

Connecting AI to Analog Signal

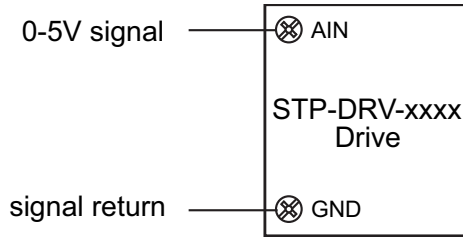

Connecting AI to Potentiometer

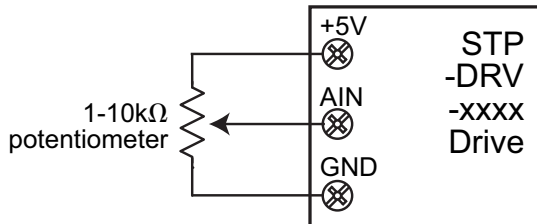

Warning: The analog input is NOT optically isolated, and must be used with care. It may operate improperly and it can be damaged if the system grounds are not compatible.

Connecting the Digital Output

The *SureStep* advanced drives have one digital output that has separate + and - terminals, and can be used to sink or source current.

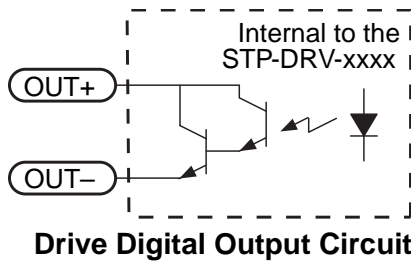

Connecting DO to Inductive Load

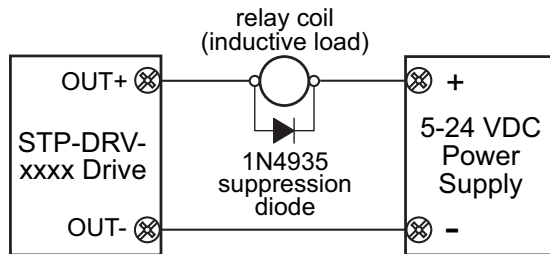

Connecting DO as Sinking Output

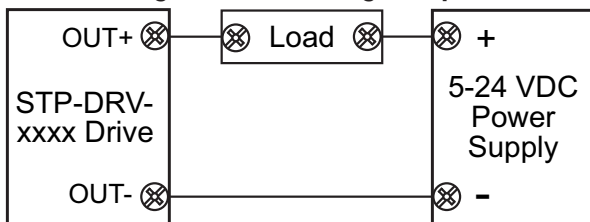

Connecting DO as Sourcing Output

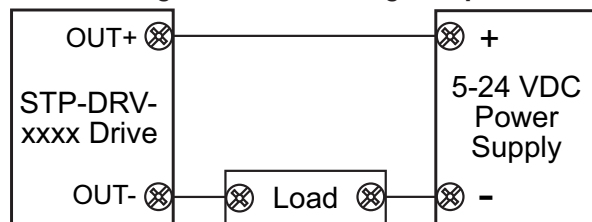

Warning: Do NOT connect the digital output to a voltage greater than 30 VDC. The current through each DO terminal must not exceed 100 mA.

Drive Configuration

You need to configure your drive for your particular application before using the drive for the first time. The *SureStep* advanced microstepping drives include a CD containing *SureStep*™ Pro drive configuration software for this purpose. The software contains instructions for installation on a PC, and instructions for configuring the drives. Configuration settings include:

- drive model
- motor characteristics
- motion control mode
- I/O configuration

Anti-Resonance / Electronic Damping

Step motor systems have a tendency to resonate at certain speeds. *SureStep* advanced drives automatically calculate the system's natural resonate frequency, and apply damping to the control algorithm. This greatly improves midrange stability, allows higher speeds and greater torque utilization, and improves settling times.

This feature is on by default, but it can be turned off using the "Motor..." icon of the *SureStep* Pro software.

Idle Current Reduction

This feature reduces current consumption while the system is idle, and subsequently reduces drive and motor heating. However, reducing the idle current also reduces the holding torque.

The percent and delay time of the idle current reduction can be adjusted using the "Motor..." icon of the *SureStep* Pro software.

Microstep Resolution

The microstep resolution (steps/rev) can be selected using the "Motion & I/O..." icon of the *SureStep* Pro software, and selecting "Pulse and Direction Mode".

Modes of Operation

Modes of operation are selectable via the *SureStep* Pro software "Motion & I/O..." icon.

- Pulse & Direction Mode
 - Pulse & Direction
 - CW & CCW Pulse
 - A/B Quadrature
- Velocity (Oscillator) Mode
- Serial Command Language (SCL)

Phase Current Setting

Motor phase current settings are available through the *SureStep* Pro software "Motor..." icon and the "Running Current" settings.

Serial Command Language (SCL) Host Control

SureStep advanced drives can accept serial commands from a host PC or PLC. This feature can be selected using the “Motion & I/O...” icon of the *SureStep* Pro software, and selecting Serial Command Language.

Step Smoothing Filter (Command Signal Smoothing & Microstep Emulation)

The Step Smoothing Filter setting is effective only in the Step (Pulse) & Direction mode. It includes command signal smoothing and microstep emulation to soften the effect of immediate changes in velocity and direction, therefore making the motion of the motor less jerky. An added advantage is that it can reduce the wear on mechanical components.

This feature can be modified by using the “Motion & I/O...” icon of the *SureStep* Pro software, and selecting “Pulse and Direction Mode”.

Waveform (Torque Ripple) Smoothing

All step motors have an inherent low speed torque ripple that can affect the motion of the motor. *SureStep* advanced drives can analyze this torque ripple and apply a negative harmonic to negate this effect. This feature gives the motor much smoother motion at low speeds.

This feature is on by default, and is factory preset for standard motors. It can be turned off or on using the “Motor...” icon of the *SureStep* Pro software. To set Waveform Smoothing for custom motors, select “Define Custom Motor...” and the “Waveform Smoothing” “Wizard...”.

SureStep™ Pro Software

The SureStep advanced drives STP-DRV-4850 & -80100 are configured using SureStep Pro™ configuration software, which is included on CD with the drive.

The software is divided into two major sections, “Motion and I/O” and “Motor” configuration. There are also communication settings, drive selection, and drive status features.

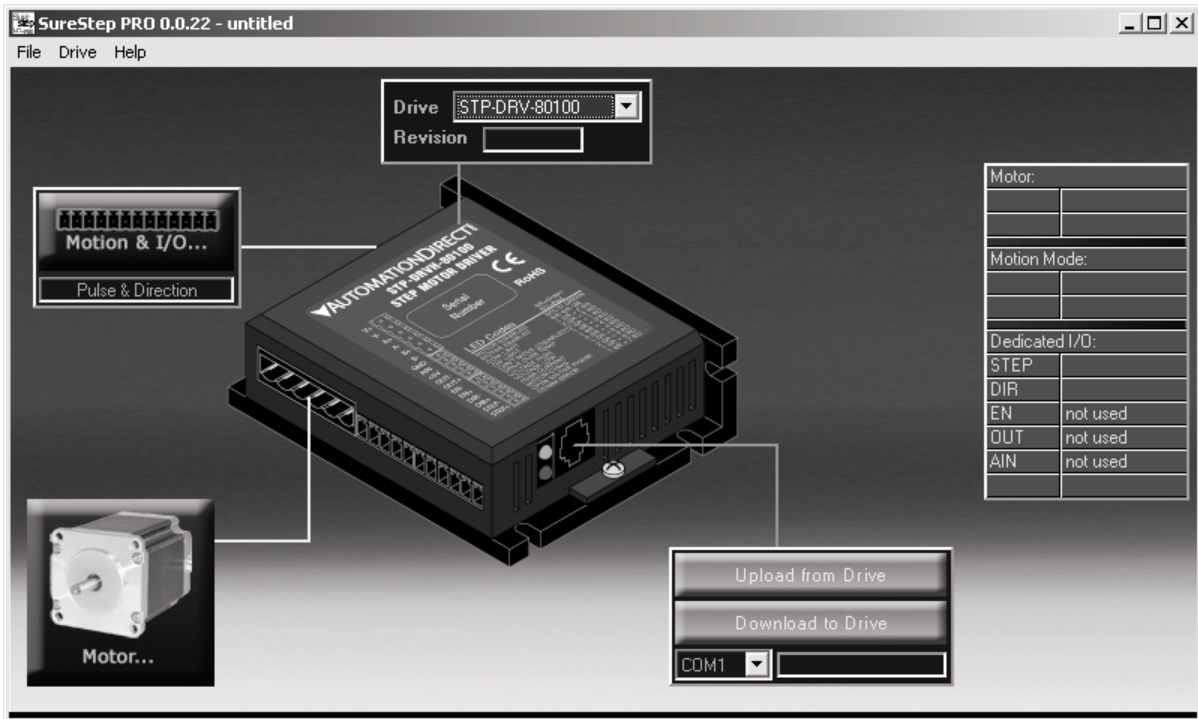

Complete software instructions are included in the “Help” files within the software.

Communication:

Upload and Download from/to the drive. When you connect to a drive, the Motor, Motion Mode, and Dedicated I/O settings that are currently in the drive will appear on the right of the screen (as will the Drive and Revision at the top of the screen). “Upload from Drive” to get all the configuration settings from the drive or “Download to Drive” to apply all the settings on the PC to the drive.

Motor Configuration:

Clicking on the “Motor..” icon will bring up the motor configuration screen. You can choose a motor from the pull-down menu or enter a custom motor (you will need to enter that motor’s specific information). If you know the inertia mismatch of the load, you should enter it. If the inertia mismatch is unknown, this entry can be left at 1. The idle current is default at 50%. Idle current should be used unless the application will require a constant high holding torque

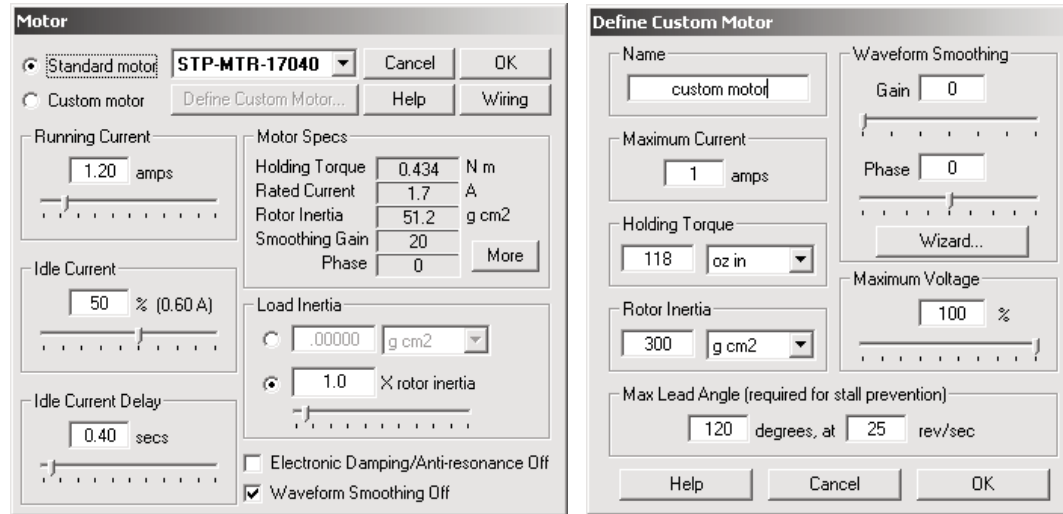

Motion and I/O:

Selecting this tab will allow you to set the drive’s mode of operation.

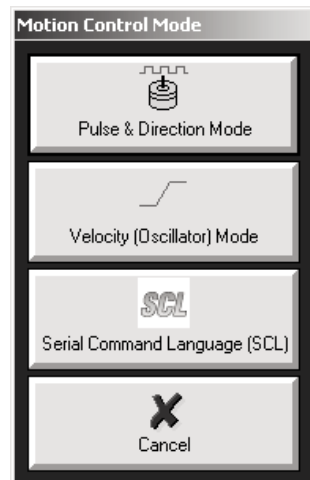

- Pulse and Direction:
 - Used with high-speed pulse inputs (CW/CCW, Pulse/Direction, Quadrature) generated from a PLC, encoder, etc.
- Velocity (Oscillator):
 - Allows the drive to be speed controlled by an analog signal. The input is 0 – 5V and can be scaled to the desired maximum speed. Bidirectional motion can be attained by changing the Offset (under “Advanced Analog Settings”) to a non-zero value. EX: Setting this value to 2500mV will command the drive to be at zero speed when 2.5V are present.
- Serial Command Language (SCL):
 - Causes the drive to respond to serial commands. A PLC or PC can issue a variety of commands to enable simple motion, gearing/following, turn on the output, wait for an input, etc. See the “SCL Manual” under the SureStep Pro Help menu. Serial commands can be tested by selecting the “Drive” pull-down menu from the menu bar, and then selecting “SCL Terminal”.

Drive Pull-down Menu:

This software menu gives you several features to monitor and test the drive.

- Alarm History – Will read back the most recent drive faults
- Clear Alarm – Will clear the current drive fault.
- Restore Factory Defaults – resets the drive to “out of the box” status.
- SCL Terminal – Allows SCL commands to be tested by typing them in. (HyperTerminal is NOT a good tool for serial commands, because the drive will “time-out” if you use HyperTerminal to enter strings. SCL Terminal will send the entire string at once.)
- Self-Test – Rotates the motor clockwise and counterclockwise. (Tests motor and cabling)
- Status Monitor – Shows the current Drive and I/O status.
- Set Quick Decel Rate – Used when the drive encounters faults or overtravel limits.

Choosing a Power Supply

Voltage

Chopper drives work by switching the voltage to the motor terminals on and off while monitoring current to achieve a precise level of phase current. To do this efficiently and silently, you'll want to have a power supply with a voltage rating at least five times that of the motor. Depending on how fast you want to run the motor, you may need even more voltage. Generally, more is better; the upper limit being the maximum voltage rating of the drive itself.

If you choose an unregulated power supply, do not allow the "no load" voltage to exceed the maximum voltage rating of the drive. Unregulated supplies are rated at full load current. At lesser loads, such as when the motor is not moving, the actual voltage can be up to 1.4 times the voltage list on the power supply label. The STP-PWR-xxxx power supplies are designed to provide maximum voltage while under load, without exceeding the drive's upper voltage limit when unloaded.

Use the "...Recommended Component Compatibility" chart in the "Chapter 1: Getting Started" to select the appropriate *SureStep* power supplies for use with *SureStep* drives.

Current

The maximum supply current you will need is the sum of the two phase currents. However, you will generally need a lot less than that, depending on the motor type, voltage, speed and load conditions. That's because the *SureStep* drives use switching amplifiers, converting a high voltage and low current into lower voltage and higher current. The more the power supply voltage exceeds the motor voltage, the less current you'll need from the power supply.

We recommend the following selection procedure:

1. If you plan to use only a few drives, choose a power supply with at least twice the rated phase current of the motor.
2. If you are designing for mass production and must minimize cost, get one power supply with more than twice the rated current of the motor. Install the motor in the application and monitor the current coming out of the power supply and into the drive at various motor loads. This test will tell you how much current you really need so you can design in a lower cost power supply.

If you plan to use a regulated power supply, you may encounter a problem with current foldback. When you first power up your drive, the full current of both motor phases will be drawn for a few milliseconds while the stator field is being established. After that, the amplifiers start chopping and much less current is drawn from the power supply. If your power supply thinks this initial surge is a short circuit it may "foldback" to a lower voltage. With many foldback schemes the voltage returns to normal only after the first motor step and is fine thereafter. In that sense, unregulated power supplies are better. They are also less expensive.



SureStep[™] STP-PWR-xxxx power supplies from AutomationDirect are the best choices of DC power supply to use with *SureStep*[™] STP-DRV-xxxx microstepping drives.

Mounting the Drive

You can mount your drive on the wide or the narrow side of the chassis using #6 screws. Since the drive amplifiers generate heat, the drive should be securely fastened to a smooth, flat metal surface that will help conduct heat away from the chassis. If this is not possible, then forced airflow from a fan may be required to prevent the drive from overheating.

- Never use your drive in a space where there is no air flow or where the ambient temperature exceeds 40 °C (104 °F).
- When mounting multiple STP-DRV-xxxx drives near each other, maintain at least one half inch of space between drives.
- Never put the drive where it can get wet.
- Never allow metal or other conductive particles near the drive.

Dimensions and Mounting Slot Locations

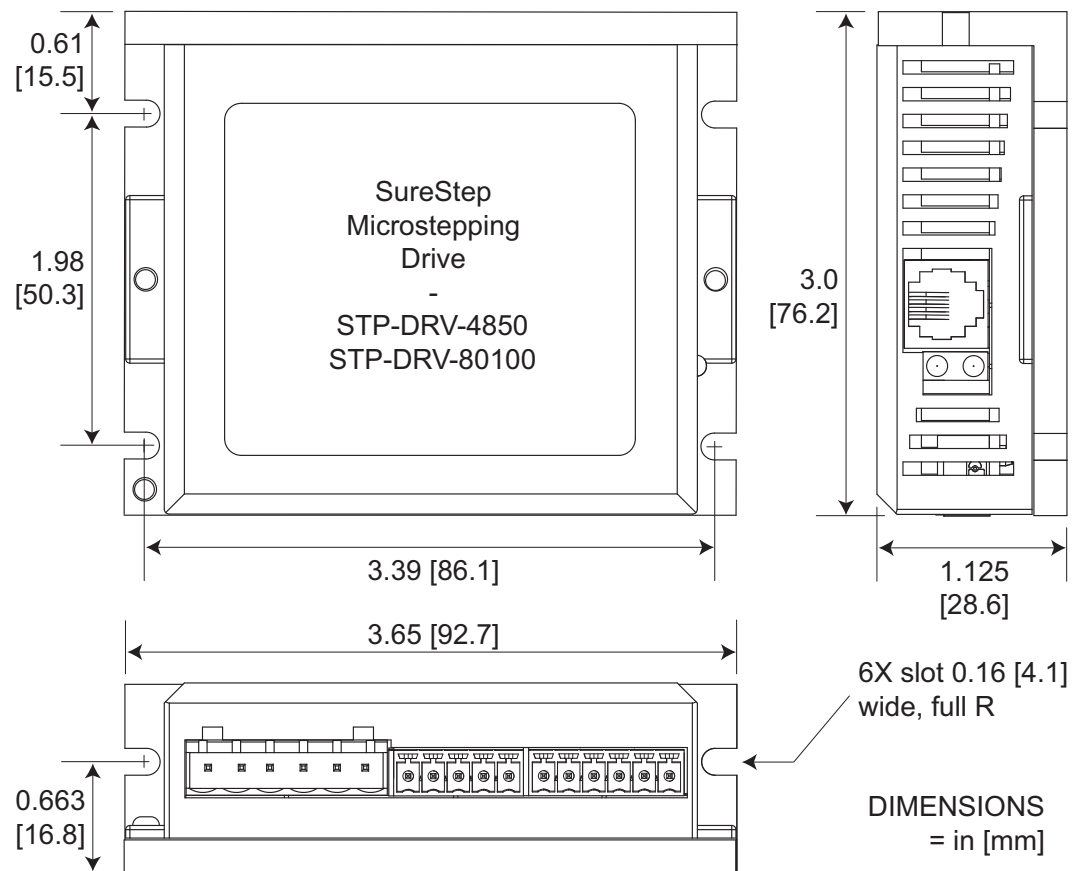

THIS PAGE
INTENTIONALLY
LEFT BLANK

SURESTEP™
STEPPING MOTORS



CHAPTER
4

In This Chapter...

Features4-2
Design and Installation Tips4-2
Specifications4-3
Power Supply and Step Motor Drive4-4
Mounting the Motor4-4
Connecting the Motor4-4
Extension Cable Wiring Diagram4-4
Motor Dimensions and Cabling4-5
Torque vs. Speed Charts4-7

Features

- Nine step motors in two torque classes and three NEMA frame sizes
- Square frame style produces high torque and achieves best torque to volume ratio
- Holding torque ranges from 61 to 1292 oz·in
- NEMA 17, 23 and 34 mounting flange frame sizes
- 4-wire, 12" long connectorized pigtail
- Optional 20 foot extension cable with locking connector available

NEMA 17



NEMA 23



NEMA 34



Motor Extension Cable



Design and Installation Tips

Allow sufficient time to accelerate the load and size the step motor with a 100% torque safety factor. DO NOT disassemble step motors because motor performance will be reduced and the warranty will be voided. DO NOT connect or disconnect the step motor during operation. Mount the motor to a surface with good thermal conductivity, such as steel or aluminum, to allow heat dissipation. Use a flexible coupling with "clamp-on" connections to both the motor shaft and the load shaft to prevent thrust loading on bearings from minor misalignment.

Specifications

SureStep™ Series Specifications – Connectorized Bipolar Stepping Motors										
Bipolar Stepping Motors		High Torque Motors					Higher Torque Motors			
		STP-MTR-17040	STP-MTR-17048	STP-MTR-23055	STP-MTR-23079	STP-MTR-34066	STP-MTRH-23079	STP-MTRH-34066	STP-MTRH-34097	STP-MTRH-34127
NEMA Frame Size		17	17	23	23	34	23	34	34	34
Max Holding Torque	(lb-in)	3.84	5.19	10.37	17.25	27.1	17.926	26.738	50.159	80.7356
	(oz-in)	61.4	83	166	276	434	286.81	427.81	802.54	1291.77
	(N-m)	0.44	0.59	1.17	1.95	3.06	2.0253	3.0210	5.6671	9.121
Rotor Inertia	(oz-in ²)	0.28	0.45	1.483	2.596	7.66	2.60	7.66	14.80	21.90
	(kg-cm ²)	0.051	0.082	0.271	0.475	1.40	0.476	1.40	2.71	4.006
Rated Current (A/phase)		1.7	2.0	2.8	2.8	2.8	5.6	6.3	6.3	6.3
Resistance (Ω/phase)		1.6	1.40	0.75	1.10	1.11	0.40	0.25	0.30	0.49
Inductance (mH/phase)		3.03	2.65	2.36	3.82	7.70	1.18	1.52	2.07	4.14
Basic Step Angle		1.8°								
Shaft Runout		0.002 in [0.051 mm]								
Max Shaft Radial Play @ 1lb load		0.001 in [0.025 mm]								
Perpendicularity		0.003 in [0.076 mm]								
Concentricity		0.002 in [0.051 mm]								
Maximum Radial Load (lb [kg])		6.0 [2.7]	15.0 [6.8]	39.0 [17.7]	15.0 [6.8]	39.0 [17.7]	6.0 [2.7]	15.0 [6.8]	39.0 [17.7]	15.0 [6.8]
Maximum Thrust Load (lb [kg])		6.0 [2.7]	13.0 [5.9]	25.0 [11.3]	13.0 [5.9]	25.0 [11.3]	6.0 [2.7]	13.0 [5.9]	25.0 [11.3]	13.0 [5.9]
Operating Temperature		-20°C to 50°C [-4°F to 122°F] (motor case temp < 100°C)								
Operating Humidity		55% to 85% non-condensing								
Weight (lb [kg])		0.7 [0.3]	1.5 [0.68]	2.2 [1.0]	3.9 [1.8]	2.3 [1.0]	3.8 [1.7]	6.1 [2.8]	8.8 [4.0]	8.8 [4.0]
Insulation Class		130°C [266°F] Class B								
Agency Approval		CE (complies with EN55014-1 (1993) and EN60034-1.5.11)								
Accessory Extension Cable		STP-EXT-020					STP-EXTH-020			

Power Supply and Step Motor Drive

An STP-PWR-xxxx series power supply from AutomationDirect is the best choice to power AutomationDirect and other step motors. These power supplies were designed to work with the AutomationDirect *SureStep*™ STP-DRV-xxxx series bipolar microstepping motor drives.

Mounting the Motor

We recommend mounting the motor to a metallic surface to help dissipate heat generated by the motor.

Connecting the Motor



WARNING: When connecting a step motor to a drive or indexer, be sure that the motor power supply is switched off. Never disconnect the motor while the drive is powered up. Never connect the motor leads to ground or directly to the power supply.

All *SureStep* step motors have four-wire connectorized pigtail cables which connect directly to available *SureStep* 20" extension cables. Due to the different current ranges of the two motor torque classes, two different cables are available with two different current capacities. The ...MTR... motors use ...EXT... cables, and the ...MTRH... motors use ...EXTH... cables. The extension cables have the same wire color coding as the motor pigtail cables, as shown in the extension cable wiring diagram and in the motor dimension and cabling diagram.

Extension Cable Wiring Diagram

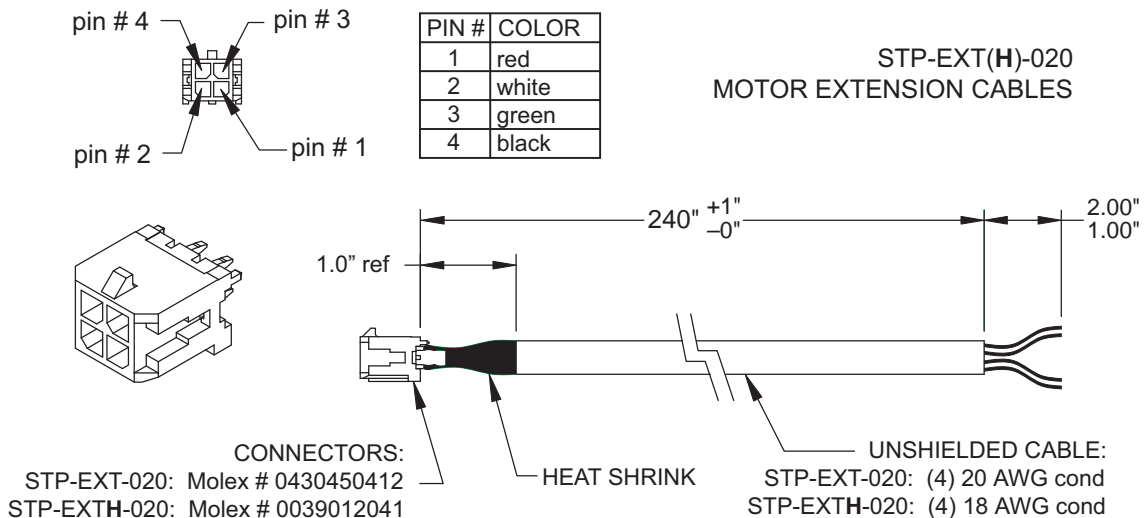

Motor Dimensions and Cabling

Typical Dimension and Cable Diagram for STP-MTR(H)-xxxxx Step Motors

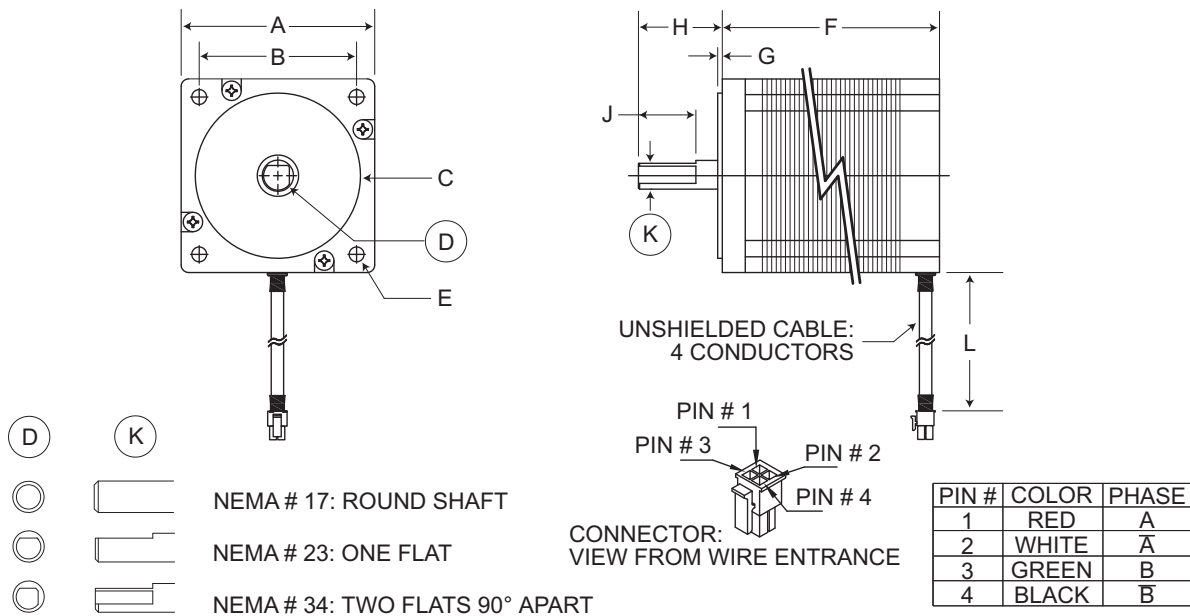

SureStep™ Series Dimensions & Cabling – STP-MTR-xxxxx** Step Motors					
Dimensions (in [mm])*	High Torque Motors STP-MTR-xxxxx**				
	STP-MTR -17040	STP-MTR -17048	STP-MTR -23055	STP-MTR -23079	STP-MTR-34066
A	1.67 [42.42]	1.66 [42.16]	2.25 [57.15]		3.37 [85.60]
B	1.22 [30.99]		1.86 [47.24]		2.74 [69.60]
C	Ø 0.866 [22.00] +0.000/-0.002		Ø 1.500 [38.10] ±0.001		Ø2.875[73.03]±0.001
D	Ø 0.1968 [5.00] +0.0000/-0.0005		Ø 0.2500 [6.35] +0.0000/-0.0005		Ø 0.5000 [12.70] +0.0000/-0.0005
E	M3 x 0.5 thread 0.15 [3.81] min depth		Ø 0.20 [5.08] through		Ø 0.26 [6.60] through
F	1.58 [40.13]	1.89 [48.00]	2.17 [55.12]	3.10 [78.74]	2.60 [66.04]
G	0.08 [2.03]		0.06 [1.52]		0.08 [2.03]
H	0.94 [23.88] ±0.02		0.81 [20.57] ±0.02		1.46 [37.08] ±0.04
J	n/a		0.59 [14.99]		1.00 [25.40]
K	n/a		0.230 [5.84]		0.450 [11.43] ±0.006
L	12 [305] +0.5/-0.0	12.0 [305]			
Conductor	(4) #20 AWG				
Connector	Molex # 43025-0400				
Pin	Molex # 43030-0007				

* mm dimensions are for reference purposes only.
 ** Higher Torque STP-MTRH-xxxxx motors are shown in a separate table.

Typical Dimension and Cable Diagram for STP-MTR(H)-xxxxx Step Motors

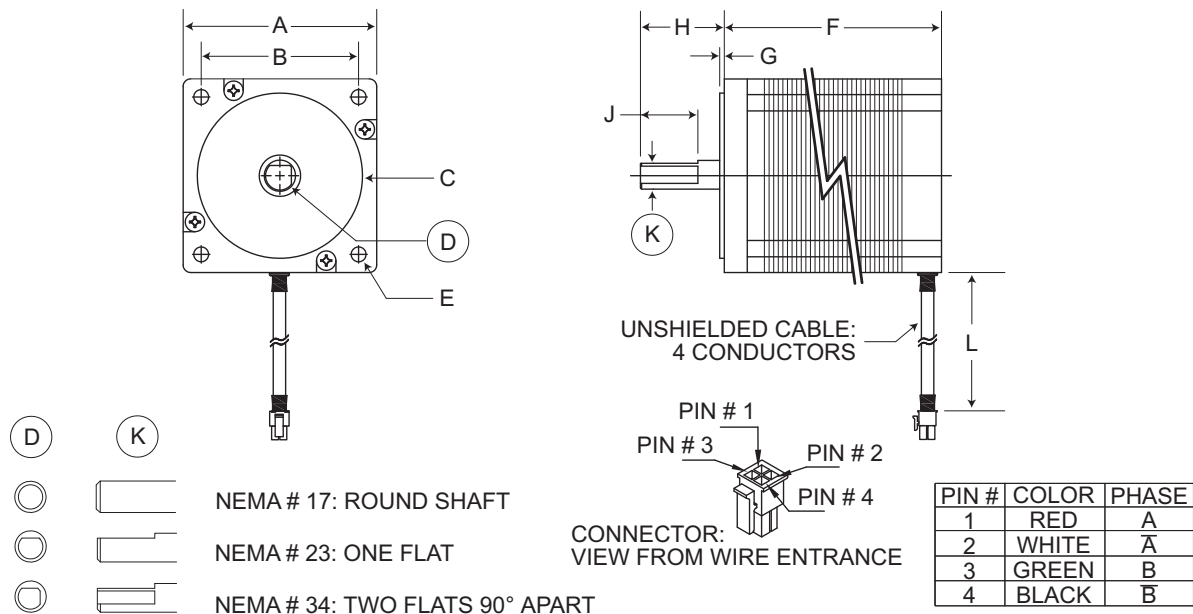

SureStep™ Series Dimensions & Cabling – STP-MTRH-xxxxx** Step Motors				
Dimensions (in [mm])*	Higher Torque Motors STP-MTRH-xxxxx**			
	STP-MTRH-23079	STP-MTRH-34066	STP-MTRH-34097	STP-MTRH-34127
A	2.25 [57.15]		3.39 [86.11]	
B	1.86 [47.24]		2.74 [69.60]	
C	∅ 1.500 [38.10] ±0.001		∅ 2.875 [73.03] ±0.001	
D	∅ 0.2500 [6.35] +0.0000/-0.0005		∅ 0.5000 [12.70] +0.0000/-0.0005	
E	∅ 0.20 [5.08] through		∅ 0.26 [6.60] through	
F	3.10 [78.74]	2.64 [67.06]	3.82 [97.03]	5.0 [127.0]
G	0.06 [1.52]		0.08 [2.03]	
H	0.81 [20.57] ±0.02		1.46 [37.08] ±0.04	
J	0.59 [14.99]		0.984 [24.99] ±0.010	
K	0.230 [5.84]		0.453 [11.51] ±0.006	
L		12 [305] +0.5/-0.0		
Conductor	(4) #18 AWG			
Connector	Molex # 39-01-3042			
Pin	Molex # 39-00-0039			
* mm dimensions are for reference purposes only.				
** High Torque STP-MTR-xxxxx motors are shown in a separate table.				

Torque vs. Speed Charts

STP-MTR-17xxx NEMA 17 Step Motors

STP-MTR-17040 Torque vs Speed (1.8° step motor; 1/2 stepping)

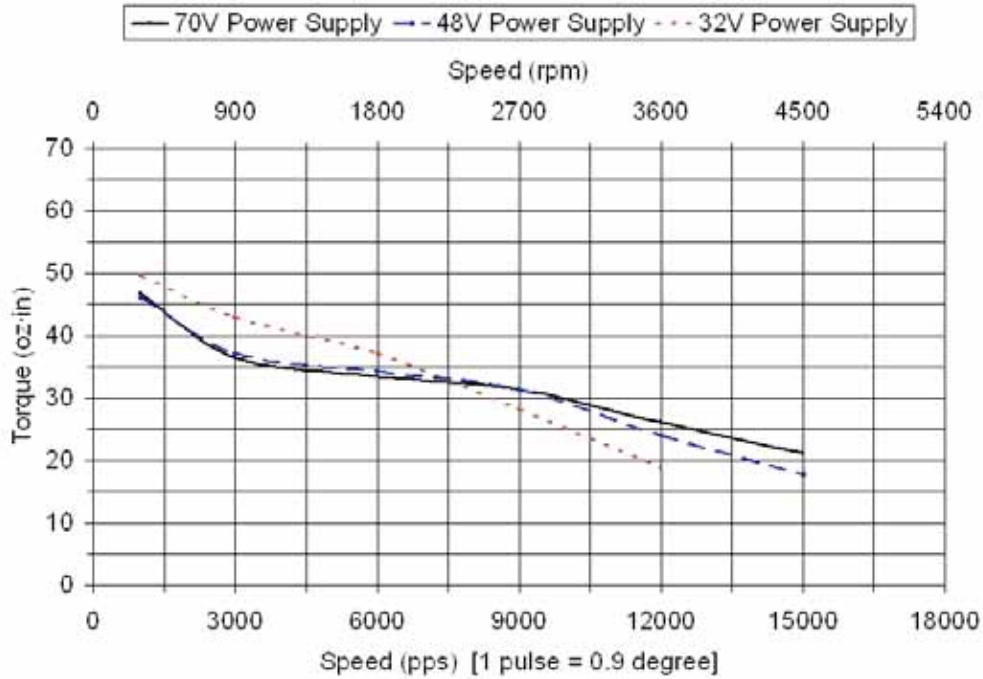

STP-MTR-17048 Torque vs Speed (1.8° step motor; 1/2 stepping)

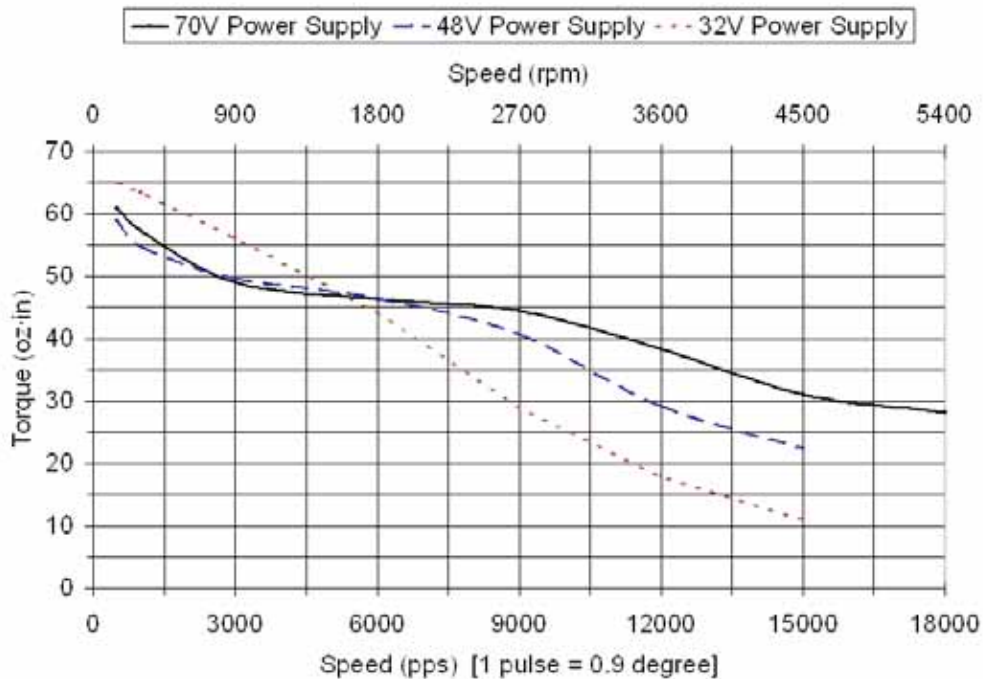

Torque vs. Speed Charts (continued)

STP-MTR(H)-23xxx NEMA 23 Step Motors

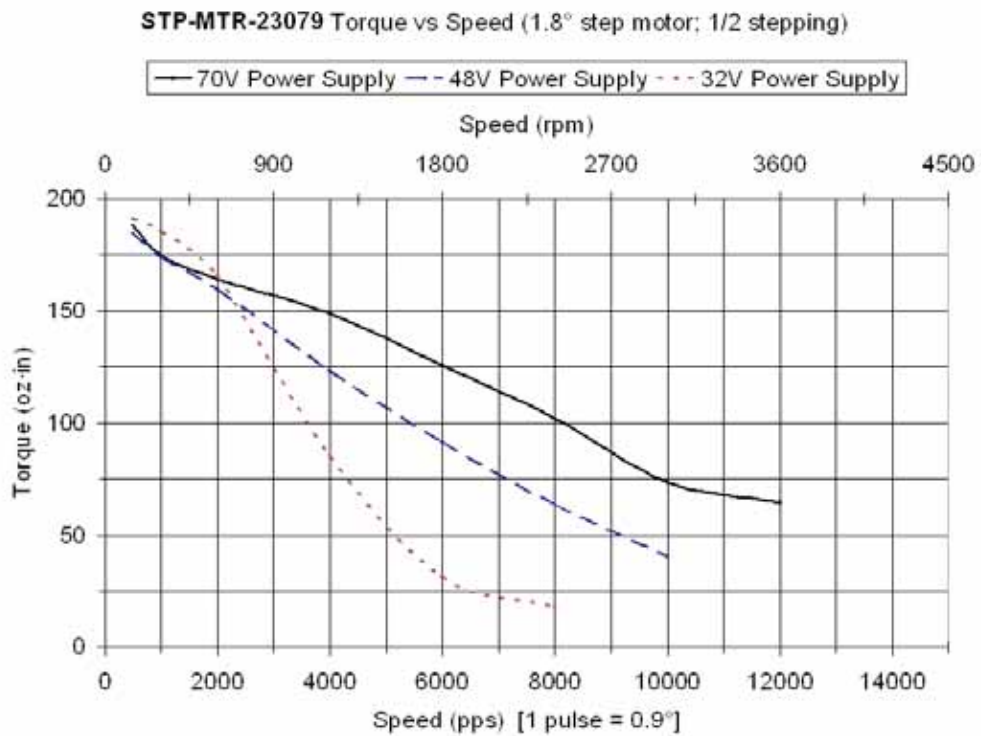
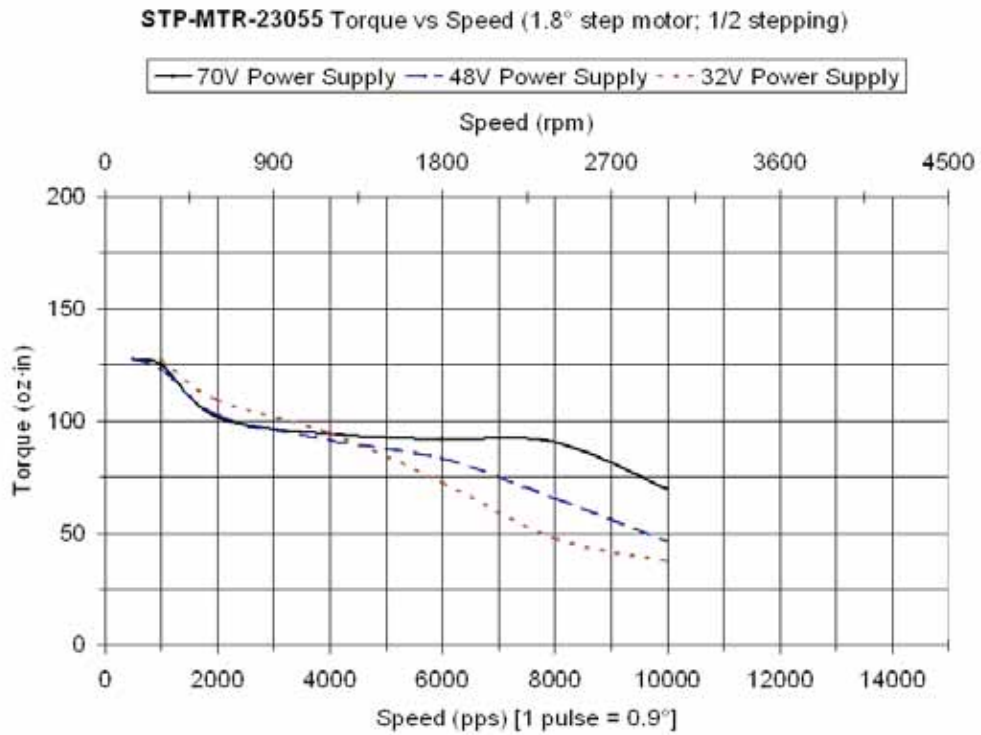

Torque vs. Speed Charts (continued)

STP-MTR(H)-23xxx NEMA 23 Step Motors (continued)

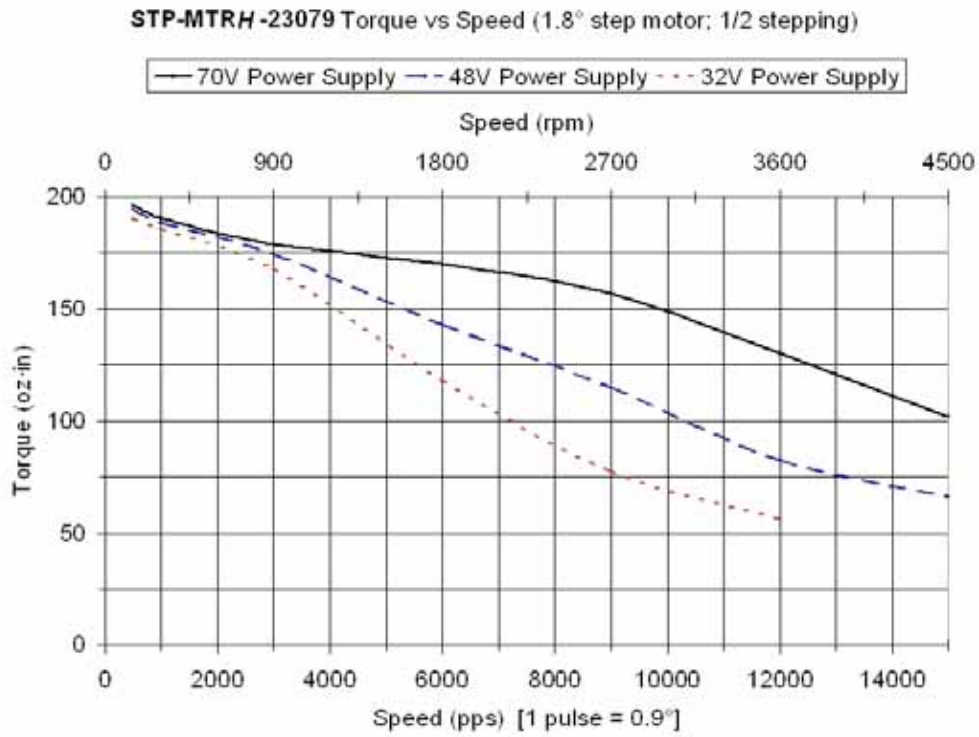

Torque vs. Speed Charts (continued)

STP-MTR(H)-34xxx NEMA 34 Step Motors

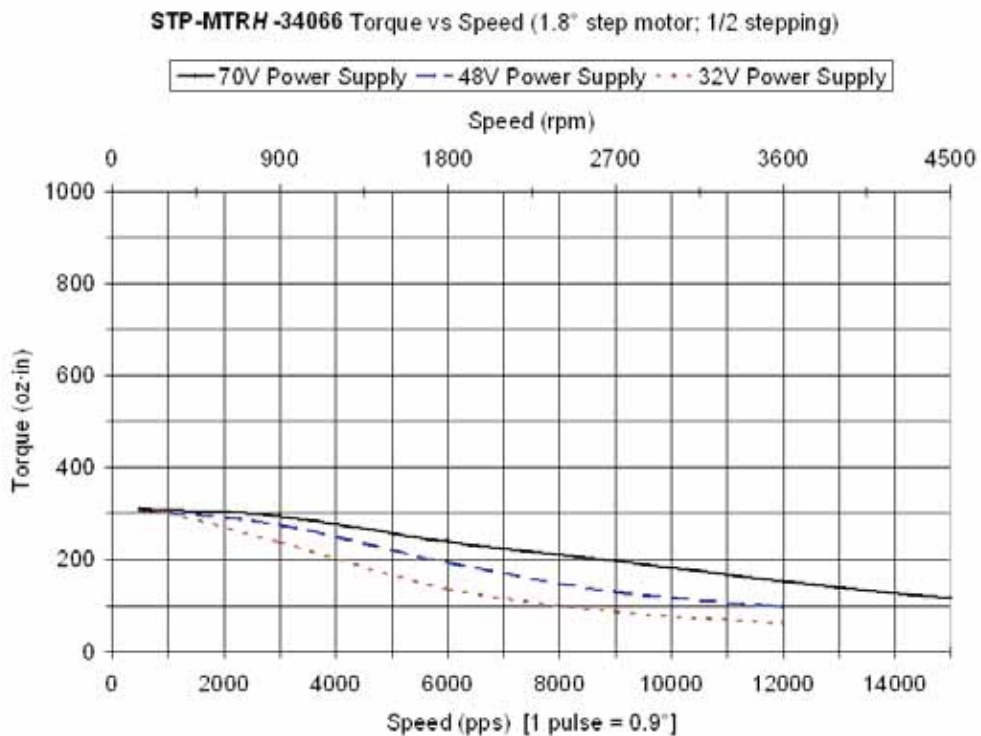
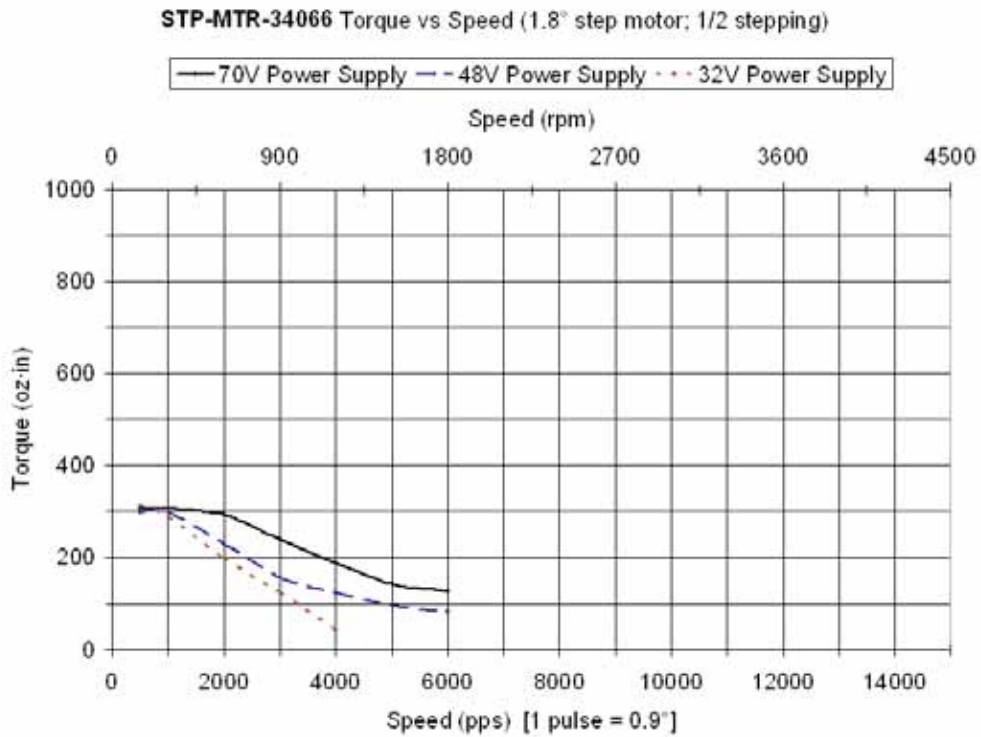

Torque vs. Speed Charts (continued)

STP-MTR(H)-34xxx NEMA 34 Step Motors (continued)

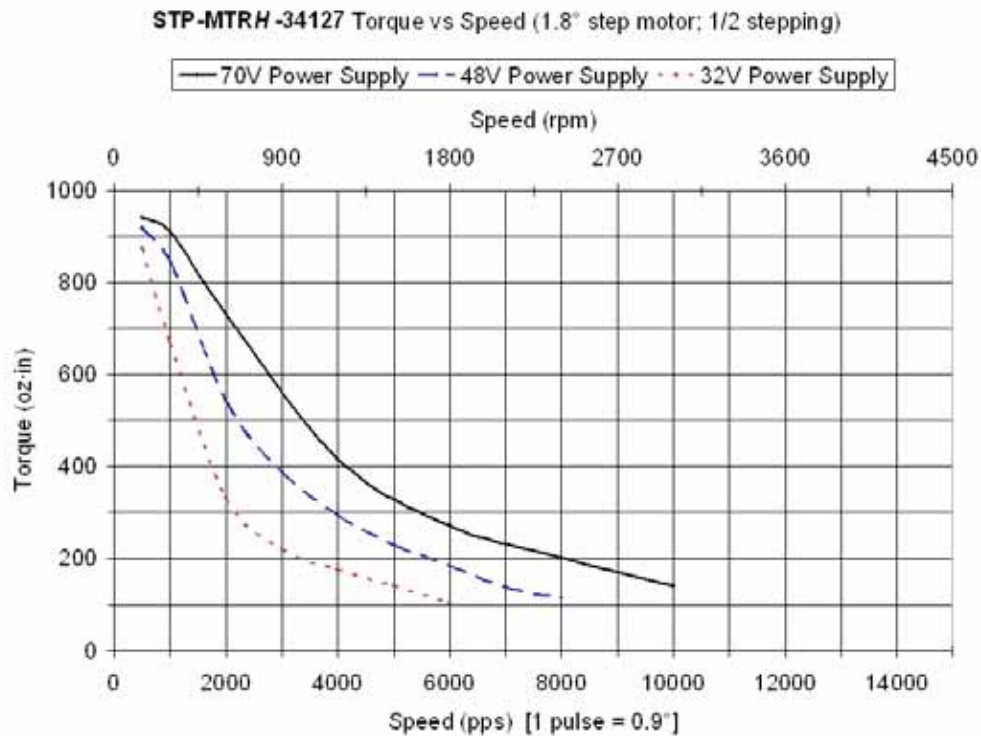
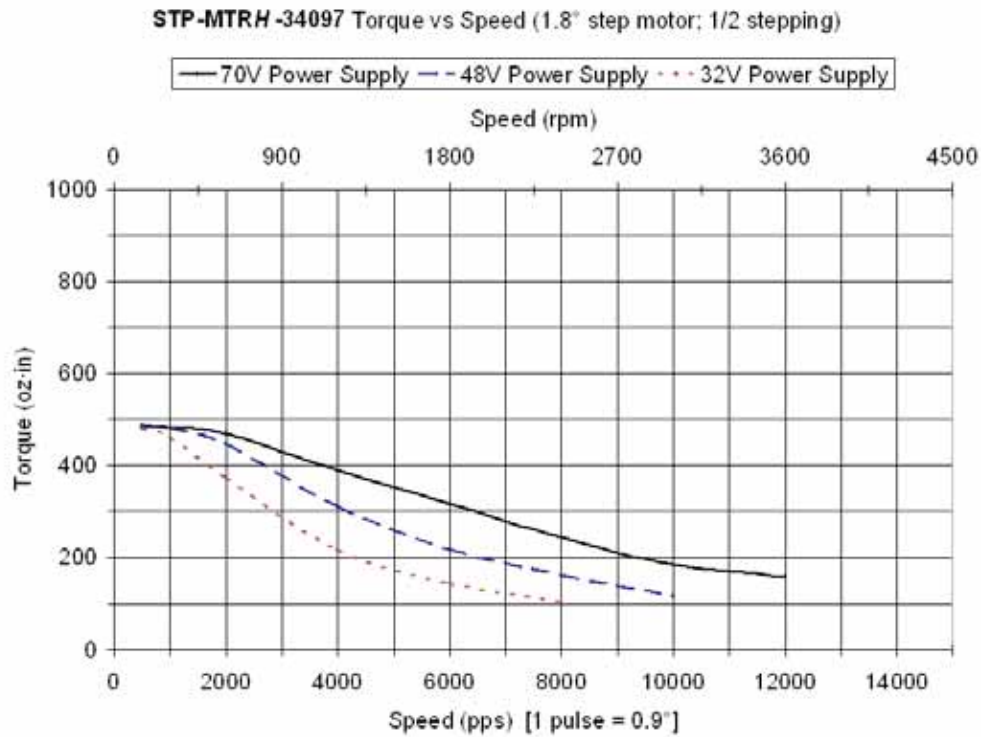

THIS PAGE
INTENTIONALLY
LEFT BLANK

SURESTEP™
STEPPING SYSTEM
POWER SUPPLIES



CHAPTER
5

In This Chapter...

Features5-2
Specifications5-3
Power Supply Terminal & Component Layout5-4
Mounting the Power Supply5-5
Dimensions5-6

Features

- Models available with 32V@4A, 48V@5A, 48V@10A, & 70V@5A DC unregulated step motor power
- 5VDC \pm 5% at 500 mA regulated logic power (electronic overload)
- Screw terminal AC input and DC output connectors
- 120 or 240 VAC, 50/60 Hz power input, switch selectable
- Power ON LEDs
- Integrated input and output fusing
- Matched to SureStep drives for maximum voltage



The stepping system power supplies can supply power for multiple SureStep STP-DRV-xxxx microstepping motor drives, depending on step motor size and application requirements.

Specifications

SureStep™ Power Supply Specifications				
Part Number	STP-PWR-3204	STP-PWR-4805	STP-PWR-4810	STP-PWR-7005
Input Power (fuse protected) ¹⁾	1-phase, 120/240 VAC, 50/60 Hz, 150 VA Fuse ¹⁾ : 3A	1-phase, 120/240 VAC, 50/60 Hz, 350 VA Fuse ¹⁾ : 5A	1-phase, 120/240 VAC, 50/60 Hz, 650 VA Fuse ¹⁾ : 8A	1-phase, 120/240 VAC, 50/60 Hz, 500 VA Fuse ¹⁾ : 7A
Input Voltage	120/240 VAC ±10% (switch selectable; voltage range switch is set to 240 VAC from factory)			
Inrush Current	120 VAC < 12A 240 VAC < 14A	120 VAC < 20A 240 VAC < 24A	120 VAC < 40A 240 VAC < 50A	
Motor Supply Output (linear unregulated, fuse protected ¹⁾ , power on LED indicator)	32 VDC @ 4A (full load) 35 VDC @ 1A load 41 VDC @ no load Fuse ¹⁾ : 6A	46.5 VDC @ 5A (full load) 52 VDC @ 1A load 57.5 VDC @ no load Fuse ¹⁾ : 8A	46.5 VDC @ 10A (full load) 50 VDC @ 1A load 57.5 VDC @ no load Fuse ¹⁾ : 15A	70 VDC @ 5A (full load) 79 VDC @ 1A load 86.5 VDC @ no load Fuse ¹⁾ : 8A
SureStep Drive Compatibility ²⁾	STP-DRV-4035 (STP-DRV-4850) (STP-DRV-80100)	STP-DRV-4850 (STP-DRV-80100)		STP-DRV-80100
Logic Supply Output	5VDC ±5% @ 500 mA (regulated, electronically overload protected, power on LED indicator)			
Operating Temperature	0 to 50 °C (32 to 122 °F) full rated; 70 °C (158 °F) maximum Derate current 1.1% per degree above 50 °C			
Storage Temperature	-55 to 85 °C -67 to 185 °F			
Humidity	95% (non-condensing) relative humidity maximum			
Cooling Method	Natural convection (mount power supply to metal surface if possible)			
Dimensions (in [mm])	4.00 x 7.00 x 3.25 [101.6x177.8x82.6]	5.00 x 8.10 x 3.88 [127.0x205.7x98.6]	5.62 x 9.00 x 4.62 [142.7 x 228.6 x 117.3]	
Mounting	Use four (4) #10 screws to mount on either wide or narrow side.			
Weight (lb [kg])	6.5 [2.9]	11 [4.9]	18 [8.3]	16 [7.2]
Connections	Screw Terminals			
Agency Approvals	UL (file # E181899), CSA, CE			
<p>1) Fuses to be replaced by qualified service personnel only. Use (1-1/4 x 1/4 in) ceramic fast-acting fuses (Edison type ABC from AutomationDirect, or equivalent).</p> <p>2) Caution: Do not use a power supply that exceeds the input voltage range of the drive. Using a lower voltage power supply with a higher voltage drive is acceptable, but will not provide full system performance.</p>				

Power Supply Terminal & Component Layout

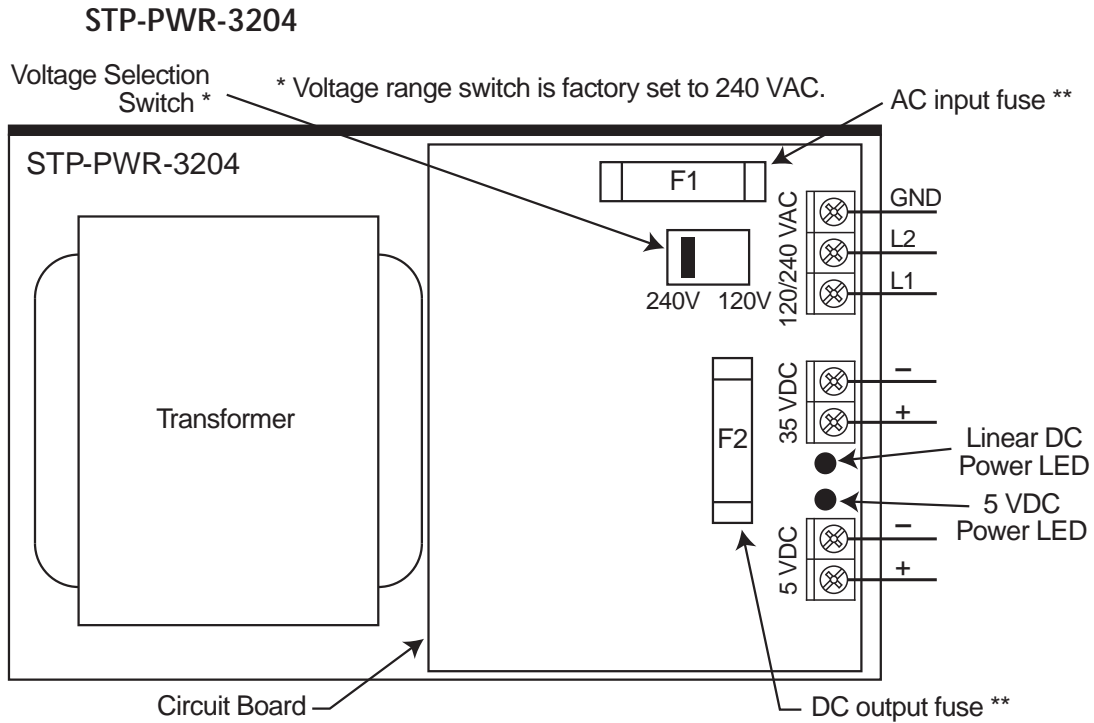

** Fuses are listed in power supply specifications table.
 ** Fuses to be replaced by qualified service personnel only.

STP-PWR-4805, STP-PWR-4810, STP-PWR-7005

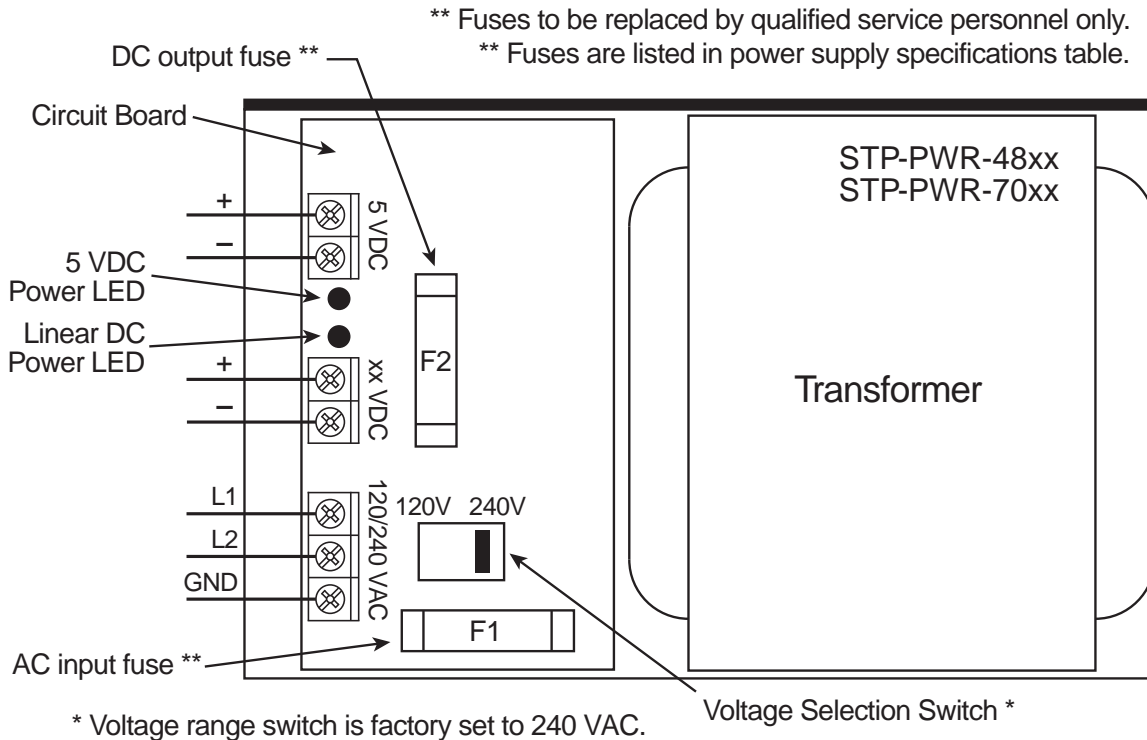

Mounting the Power Supply

STP-PWR-xxxx power supplies can be mounted on either the bottom (wide) side, or the back (narrow) side of the chassis. Either orientation contains mounting holes for machine screws. Use #10 screws for STP-PWR-3204 and -4805, or 1/4" screws for STP-PWR-4810 and -7005.

Since power supplies generate heat, they should be mounted in a location that allows air flow. They also should be securely fastened to a smooth, flat metal surface that will dissipate heat.

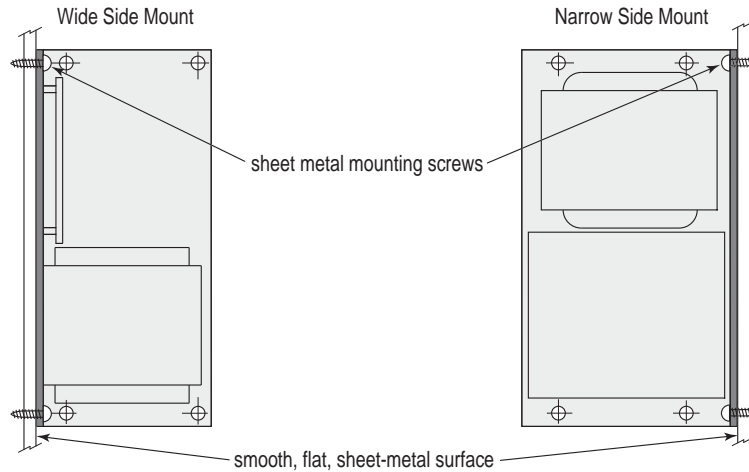

Warning: Never use the power supply in a space where there is no air flow, or where the surrounding air temperature is greater than 70 °C.

Dimensions

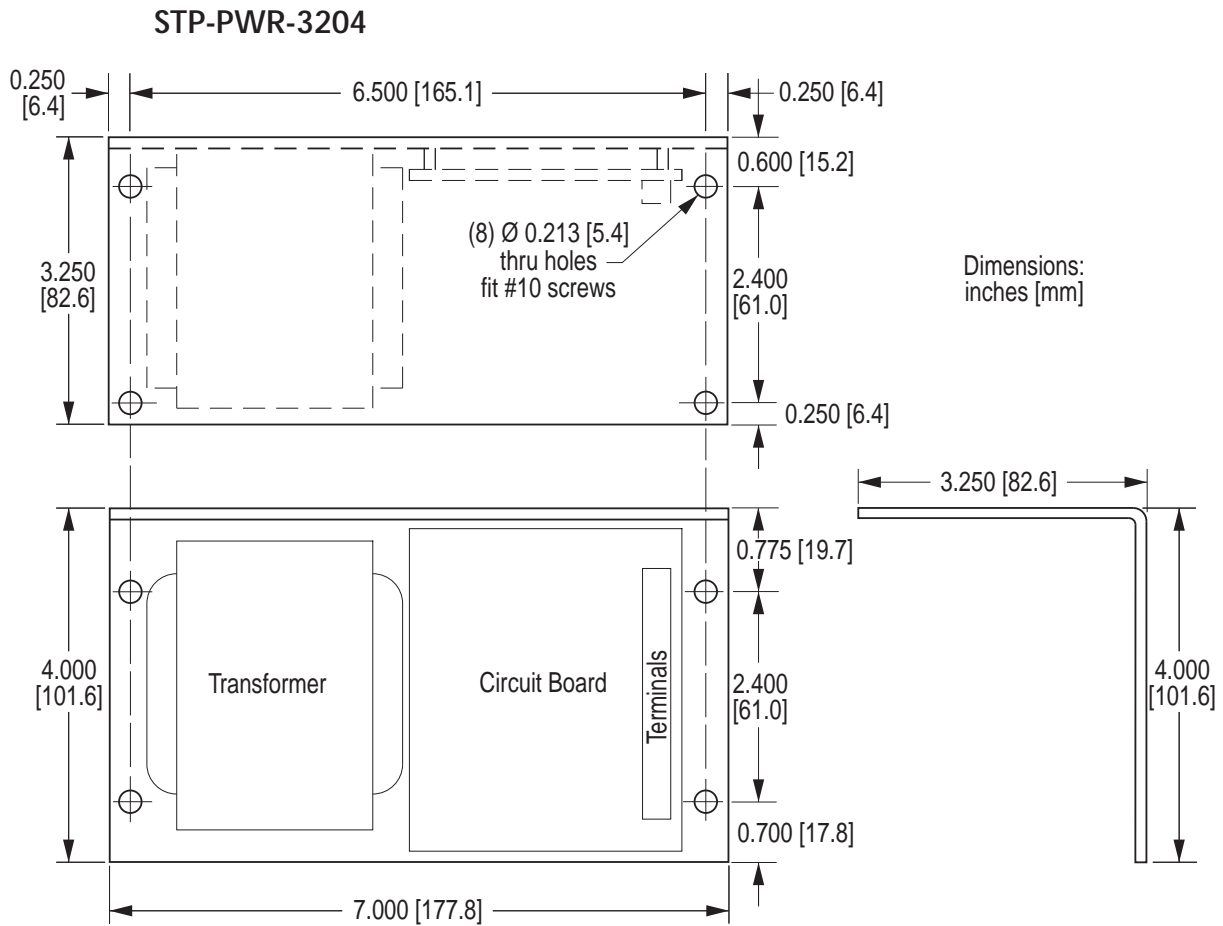

Dimensions (continued)

STP-PWR-4805, -4810, -7005

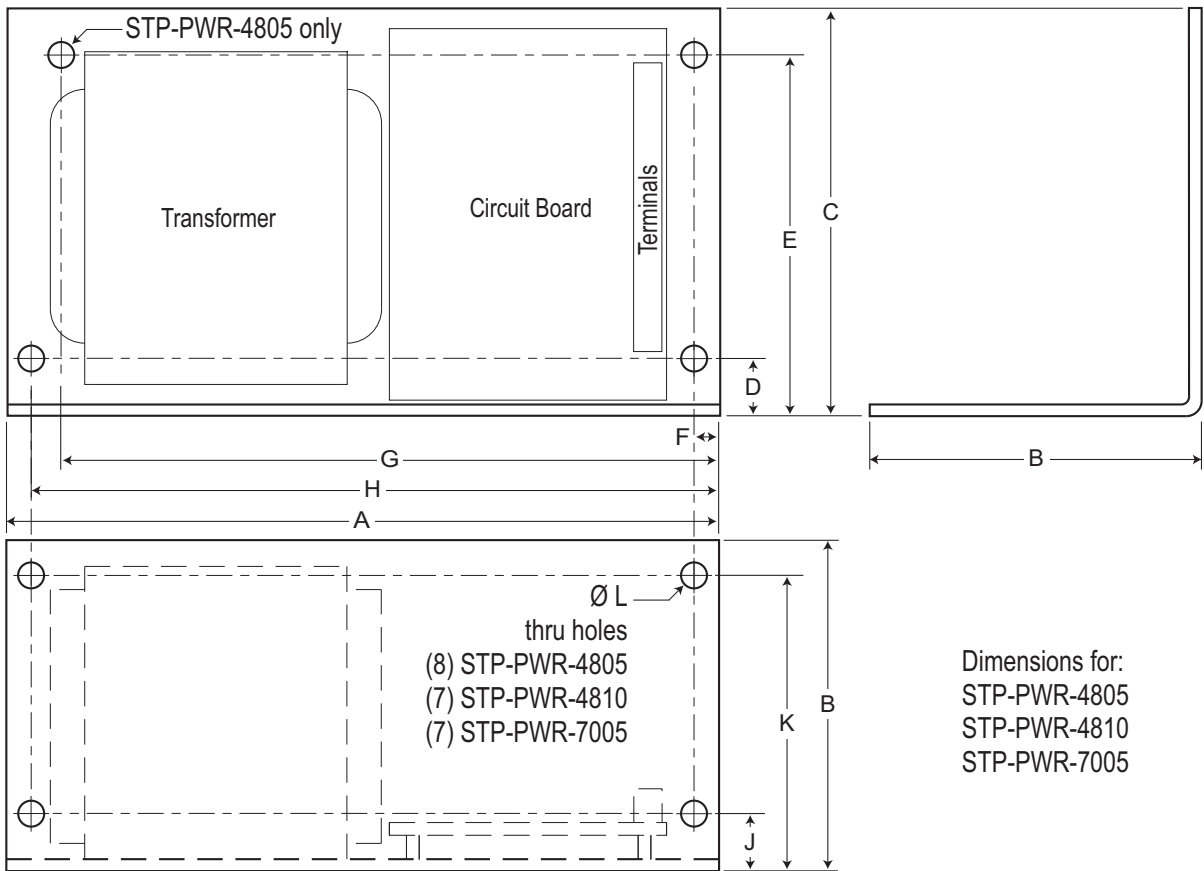

SureStep™ Series Dimensions – 48V & 70V Power Supplies			
Dimensions* (in [mm]*)	Power Supply Part Number		
	STP-PWR-4805	STP-PWR-4810	STP-PWR-7005
A	8.10 [205.7]	9.00 [228.6]	
B	3.88 [98.6]	4.62 [117.3]	
C	5.00 [127.0]	5.62 [142.7]	
D	0.87 [22.1]	1.56 [39.6]	
E	4.67 [118.6]	4.06 [103.1]	
F	0.25 [6.4]	0.35 [8.9]	
G	7.15 [181.6]	n/a	
H	7.75 [196.9]	8.59 [218.2]	
J	0.50 [12.7]	0.50 [12.7]	
K	3.53 [89.7]	4.27 [108.5]	
L	0.200 [5.1]	9/32 [7.1]	
Mtg Screw	#10	1/4	

** mm dimensions are for reference purposes only.*

THIS PAGE
INTENTIONALLY
LEFT BLANK

SELECTING THE *SureStep*[™] STEPPING SYSTEM



APPENDIX

A

In This Appendix...

Selecting the <i>SureStep</i> [™] Stepping System	A-2
The Selection Procedure	A-2
How many pulses from the PLC to make the move?	A-2
What is the positioning resolution of the load?	A-3
What is the indexing speed to accomplish the move time?	A-3
Calculating the Required Torque	A-4
Leadscrew - Example Calculations	A-8
Step 1 - Define the Actuator and Motion Requirements	A-8
Step 2 - Determine the Positioning Resolution of the Load	A-8
Step 3 - Determine the Motion Profile	A-9
Step 4 - Determine the Required Motor Torque	A-9
Step 5 - Select & Confirm Stepping Motor & Driver System	A-10
Belt Drive - Example Calculations	A-11
Step 1 - Define the Actuator and Motion Requirements	A-11
Step 2 - Determine the Positioning Resolution of the Load	A-11
Step 3 - Determine the Motion Profile	A-12
Step 4 - Determine the Required Motor Torque	A-12
Step 5 - Select & Confirm Stepping Motor & Driver System	A-13
Index Table - Example Calculations	A-14
Step 1 - Define the Actuator and Motion Requirements	A-14
Step 2 - Determine the Positioning Resolution of the Load	A-14
Step 3 - Determine the Motion Profile	A-15
Step 4 - Determine the Required Motor Torque	A-15
Step 5 - Select & Confirm Stepping Motor & Driver System	A-16
Engineering Unit Conversion Tables, Formulae, & Definitions:	A-17

Selecting the SureStep™ Stepping System

The selection of your SureStep™ stepping system follows a defined process. Let's go through the process and define some useful relationships and equations. We will use this information to work some typical examples along the way.

The Selection Procedure

The motor provides for the required motion of the load through the actuator (mechanics that are between the motor shaft and the load or workpiece). Key information to accomplish the required motion is:

- total number of pulses from the PLC
- positioning resolution of the load
- indexing speed (or PLC pulse frequency) to achieve the move time
- required motor torque (including the 100% safety factor)
- load to motor inertia ratio

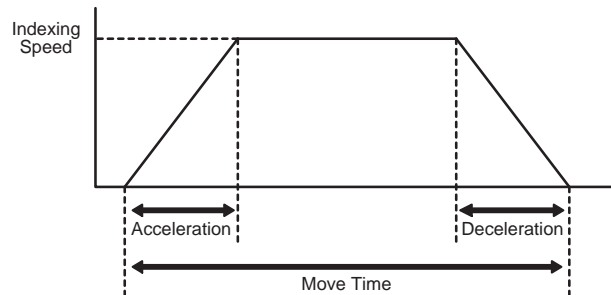

In the final analysis, we need to achieve the required motion with acceptable positioning accuracy.

How many pulses from the PLC to make the move?

The total number of pulses to make the entire move is expressed with the equation:

$$\text{Equation ①: } P_{\text{total}} = \text{total pulses} = (D_{\text{total}} \div (d_{\text{load}} \div i)) \times \theta_{\text{step}}$$

D_{total} = total move distance

d_{load} = lead or distance the load moves per revolution of the actuator's drive shaft
(P = pitch = $1/d_{\text{load}}$)

θ_{step} = driver step resolution (steps/rev_{motor})

i = gear reduction ratio (rev_{motor}/rev_{gearshaft})

Example 1: The motor is directly attached to a disk, the stepping driver is set at 400 steps per revolution and we need to move the disk 5.5 revolutions. How many pulses does the PLC need to send the driver?

$$\begin{aligned} P_{\text{total}} &= (5.5 \text{ rev}_{\text{disk}} \div (1 \text{ rev}_{\text{disk}}/\text{rev}_{\text{driveshaft}} \div 1 \text{ rev}_{\text{motor}}/\text{rev}_{\text{driveshaft}})) \\ &\quad \times 400 \text{ steps}/\text{rev}_{\text{motor}} \\ &= 2200 \text{ pulses} \end{aligned}$$

Example 2: The motor is directly attached to a ballscrew where one turn of the ballscrew results in 10 mm of linear motion, the stepping driver is set for 1000 steps per revolution, and we need to move 45 mm. How many pulses do we need to send the driver?

$$P_{\text{total}} = (45 \text{ mm} \div (10 \text{ mm/rev}_{\text{screw}} \div 1 \text{ rev}_{\text{motor}}/\text{rev}_{\text{screw}})) \times 1000 \text{ steps/rev}_{\text{motor}}$$

$$= 4500 \text{ pulses}$$

Example 3: Let's add a 2:1 belt reduction between the motor and ballscrew in example 2. Now how many pulses do we need to make the 45 mm move?

$$P_{\text{total}} = (45 \text{ mm} \div (10\text{mm/rev}_{\text{screw}} \div 2 \text{ rev}_{\text{motor}}/\text{rev}_{\text{screw}})) \times 1000 \text{ steps/rev}_{\text{motor}}$$

$$= 9000 \text{ pulses}$$

What is the positioning resolution of the load?

We want to know how far the load will move for one pulse or step of the motor shaft. The equation to determine the positioning resolution is:

Equation ②: L_{θ} = load positioning resolution = $(d_{\text{load}} \div i) \div \theta_{\text{step}}$

Example 4: What is the positioning resolution for the system in example 3?

$$L_{\theta} = (d_{\text{load}} \div i) \div \theta_{\text{step}}$$

$$= (10 \text{ mm/rev}_{\text{screw}} \div 2 \text{ rev}_{\text{motor}}/\text{rev}_{\text{screw}}) \div 1000 \text{ steps/rev}_{\text{motor}}$$

$$= 0.005\text{mm/step}$$

$$\approx 0.0002"/\text{step}$$

What is the indexing speed to accomplish the move time?

The most basic type of motion profile is a "start-stop" profile where there is no acceleration or deceleration period. This type of motion profile is only used for low speed applications because the load is "jerked" from one speed to another and the stepping motor will stall or drop pulses if excessive speed changes are attempted. The equation to find indexing speed for "start-stop" motion is:

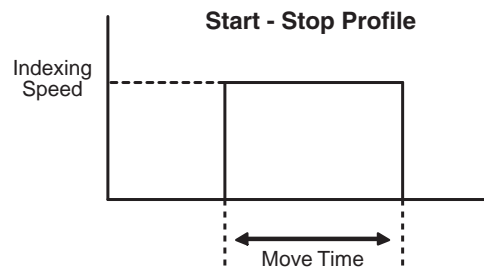

Equation ③: f_{SS} = indexing speed for start-stop profiles = $P_{\text{total}} \div t_{\text{total}}$

t_{total} = move time

Example 5: What is the indexing speed to make a "start-stop" move with 10,000 pulses in 800 ms?

$$f_{SS} = \text{indexing speed} = P_{\text{total}} \div t_{\text{total}} = 10,000 \text{ pulses} \div 0.8 \text{ seconds} \\ = 12,500 \text{ Hz.}$$

For higher speed operation, the "trapezoidal" motion profile includes controlled acceleration & deceleration and an initial non-zero starting speed. With the acceleration and deceleration periods equally set, the indexing speed can be found using the equation:

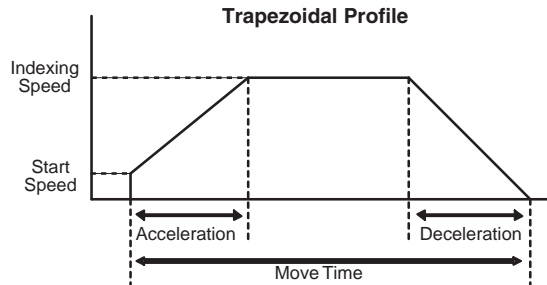

$$\text{Equation ④: } f_{\text{TRAP}} = (P_{\text{total}} - (f_{\text{start}} \times t_{\text{ramp}})) \div (t_{\text{total}} - t_{\text{ramp}}) \\ \text{for trapezoidal motion profiles}$$

f_{start} = starting speed

t_{ramp} = acceleration or deceleration time

Example 6: What is the required indexing speed to make a "trapezoidal" move in 800ms, accel/decel time of 200 ms each, 10,000 total pulses, and a starting speed of 40 Hz?

$$f_{\text{TRAP}} = (10,000 \text{ pulses} - (40 \text{ pulses/sec} \times 0.2 \text{ sec})) \div (0.8 \text{ sec} - 0.2 \text{ sec}) \\ \approx 16,653 \text{ Hz.}$$

Calculating the Required Torque

The required torque from the stepping system is the sum of acceleration torque and the running torque. The equation for required motor torque is:

$$\text{Equation ⑤: } T_{\text{motor}} = T_{\text{accel}} + T_{\text{run}}$$

T_{accel} = motor torque required to accelerate and decelerate the total system inertia (including motor inertia)

T_{run} = constant motor torque requirement to run the mechanism due to friction, external load forces, etc.

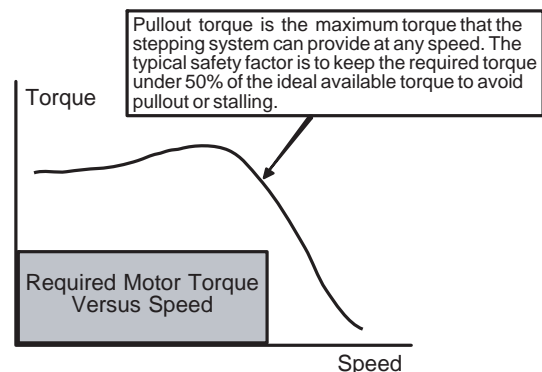

In **Table 1** we show how to calculate torque required to accelerate or decelerate an inertia from one speed to another and the calculation of running torque for common mechanical actuators.

Table 1 - Calculate the Torque for "Acceleration" and "Running"

The torque required to accelerate or decelerate an inertia with a linear change in velocity is:

Equation ⑥: $T_{\text{accel}} = J_{\text{total}} \times (\Delta\text{speed} \div \Delta\text{time}) \times (2\pi \div 60)$

J_{total} is the motor inertia plus load inertia ("reflected" to the motor shaft). The $(2\pi \div 60)$ is a factor used to convert "change in speed" expressed in RPM into angular speed (radians/second). Refer to information in this table to calculate "reflected" load inertia for several common shapes and mechanical mechanisms.

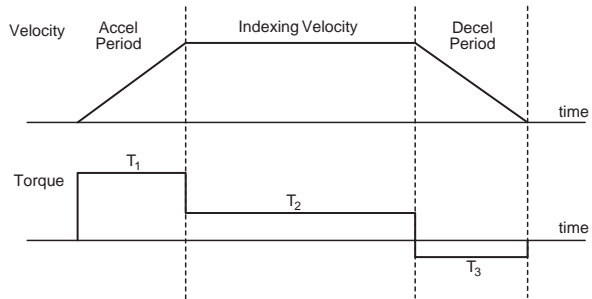

Example 7: What is the required torque to accelerate an inertia of 0.002 lb-in-sec² (motor inertia is 0.0004 lb-in-sec² and "reflected" load inertia is 0.0016 lb-in-sec²) from zero to 600 RPM in 50 ms?

$T_{\text{accel}} = 0.002 \text{ lb-in-sec}^2 \times (600 \text{ RPM} \div 0.05 \text{ seconds}) \times (2\pi \div 60)$
 $\approx 2.5 \text{ lb-in}$

Leadscrew Equations

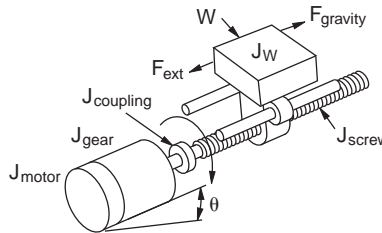

Description:	Equations:
Motor RPM	$n_{\text{motor}} = (v_{\text{load}} \times P) \times i$, n_{motor} (RPM), v_{load} (in/min)
Torque required to accelerate and decelerate the load	$T_{\text{accel}} \approx J_{\text{total}} \times (\Delta\text{speed} \div \Delta\text{time}) \times 0.1$
Motor total inertia	$J_{\text{total}} = J_{\text{motor}} + J_{\text{gear}} + ((J_{\text{coupling}} + J_{\text{screw}} + J_{\text{W}}) \div i^2)$
Inertia of the load	$J_{\text{W}} = (W \div (g \times e)) \times (1 \div 2 \pi P)^2$
Pitch and Efficiency	$P = \text{pitch} = \text{revs/inch of travel}$, $e = \text{efficiency}$
Running torque	$T_{\text{run}} = ((F_{\text{total}} \div (2 \pi P)) + T_{\text{preload}}) \div i$
Torque due to preload on the ballscrew	$T_{\text{preload}} = \text{ballscrew nut preload to minimize backlash}$
Force total	$F_{\text{total}} = F_{\text{ext}} + F_{\text{friction}} + F_{\text{gravity}}$
Force of gravity and Force of friction	$F_{\text{gravity}} = W \sin \theta$, $F_{\text{friction}} = \mu W \cos \theta$
Incline angle and Coefficient of friction	$\theta = \text{incline angle}$, $\mu = \text{coefficient of friction}$

Table 1 (cont'd)			
Typical Leadscrew Data			
Material:	e = efficiency	Material:	μ = coef. of friction
ball nut	0.90	steel on steel	0.580
acme with plastic nut	0.65	steel on steel (lubricated)	0.150
acme with metal nut	0.40	teflon on steel	0.040
		ball bushing	0.003

Belt Drive (or Rack & Pinion) Equations

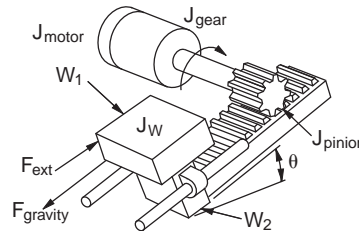
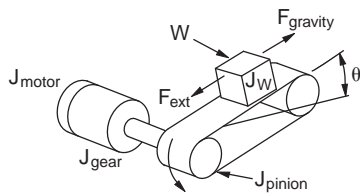

Description:	Equations:
Motor RPM	$n_{motor} = (v_{load} \times 2 \pi r) \times i$
Torque required to accelerate and decelerate the load	$T_{accel} \approx J_{total} \times (\Delta speed \div \Delta time) \times 0.1$
Inertia of the load	$J_{total} = J_{motor} + J_{gear} + ((J_{pinion} + J_W) \div i^2)$
Inertia of the load	$J_W = (W \div (g \times e)) \times r^2$; $J_W = ((W_1 + W_2) \div (g \times e)) \times r^2$
Radius of pulleys	$r = \text{radius of pinion or pulleys (inch)}$
Running torque	$T_{run} = (F_{total} \times r) \div i$
Force total	$F_{total} = F_{ext} + F_{friction} + F_{gravity}$
Force of gravity and Force of friction	$F_{gravity} = W \sin \theta$; $F_{friction} = \mu W \cos \theta$

Belt (or Gear) Reducer Equations

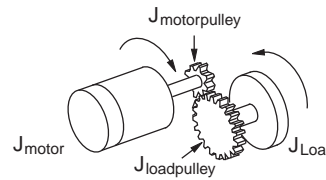
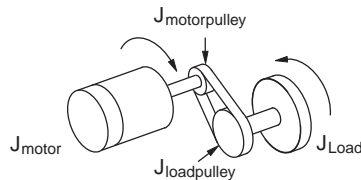

Description:	Equations:
Motor RPM	$n_{motor} = n_{load} \times i$
Torque required to accelerate and decelerate the load	$T_{accel} \approx J_{total} \times (\Delta speed \div \Delta time) \times 0.1$
Inertia of the load	$J_{total} = J_{motor} + J_{motorpulley} + ((J_{loadpulley} + J_{Load}) \div i^2)$
Motor torque	$T_{motor} \times i = T_{Load}$

Table 1 (cont'd)

Inertia of Hollow Cylinder Equations

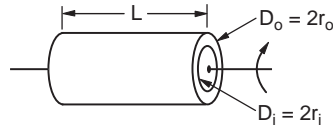

Description:	Equations:
Inertia	$J = (W \times (r_o^2 + r_i^2)) \div (2g)$
Inertia	$J = (\pi \times L \times \rho \times (r_o^4 - r_i^4)) \div (2g)$
Volume	volume = $\pi/4 \times (D_o^2 - D_i^2) \times L$

Inertia of Solid Cylinder Equations

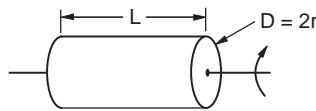

Description:	Equations:
Inertia	$J = (W \times r^2) \div (2g)$
Inertia	$J = (\pi \times L \times \rho \times r^4) \div (2g)$
Volume	volume = $\pi \times r^2 \times L$

Inertia of Rectangular Block Equations

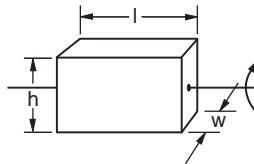

Description:	Equations:
Inertia	$J = (W \div 12g) \times (h^2 + w^2)$
Volume	volume = $l \times h \times w$

Symbol Definitions

J = inertia	ρ = density
L = Length	ρ = 0.098 lb/in ³ (aluminum)
h = height	ρ = 0.28 lb/in ³ (steel)
w = width	ρ = 0.04 lb/in ³ (plastic)
W = weight	ρ = 0.31 lb/in ³ (brass)
D = diameter	ρ = 0.322 lb/in ³ (copper)
r = radius	
g = gravity = 386 in/sec ²	$\pi \approx 3.14$

Leadscrew - Example Calculations

Step 1 - Define the Actuator and Motion Requirements

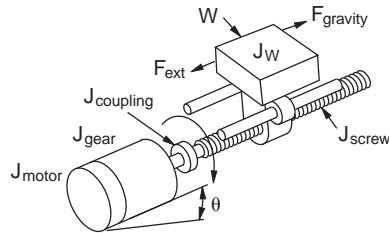

Weight of table and workpiece = 200 lb
 Angle of inclination = 0°
 Friction coefficient of sliding surfaces = 0.05
 External load force = 0
 Ball screw shaft diameter = 0.6 inch
 Ball screw length = 23.6 inch
 Ball screw material = steel
 Ball screw lead = 0.6 inch/rev ($P \approx 1.67$ rev/in)
 Desired Resolution = 0.001 inch/step
 Gear reducer = 2:1
 Stroke = 4.5 inch
 Move time = 1.7 seconds

Definitions
d_{load} = lead or distance the load moves per revolution of the actuator's drive shaft ($P = \text{pitch} = 1/d_{load}$)
D_{total} = total move distance
θ_{step} = driver step resolution (steps/rev _{motor})
i = gear reduction ratio (rev _{motor} /rev _{gearshaft})
T_{accel} = motor torque required to accelerate and decelerate the total system inertia (including motor inertia)
T_{run} = constant motor torque requirement to run the mechanism due to friction, external load forces, etc.
t_{total} = move time

Step 2 - Determine the Positioning Resolution of the Load

Rearranging Equation ④ to calculate the required stepping drive resolution:

$$\begin{aligned} \theta_{step} &= (d_{load} \div i) \div L_{\theta} \\ &= (0.6 \div 2) \div 0.001 \\ &= 300 \text{ steps/rev} \end{aligned}$$

With the 2:1 gear reduction, the stepping system can be set at 400 steps/rev to exceed the required load positioning resolution.

A 2:1 timing belt reducer is a good choice for low cost and low backlash. Also, the motor can be repositioned back under the leadscrew if desired with a timing belt reducer.

Step 3 - Determine the Motion Profile

From Equation ①, the total pulses to make the required move is:

$$\begin{aligned} P_{\text{total}} &= (D_{\text{total}} \div (d_{\text{load}} \div i)) \times \theta_{\text{step}} \\ &= (4.5 \div (0.6 \div 2)) \times 400 = 6,000 \text{ pulses} \end{aligned}$$

From Equation ④, the indexing frequency for a trapezoidal move is:

$$\begin{aligned} f_{\text{TRAP}} &= (P_{\text{total}} - (f_{\text{start}} \times t_{\text{ramp}})) \div (t_{\text{total}} - t_{\text{ramp}}) \\ &= (6,000 - (100 \times 0.43)) \div (1.7 - 0.43) \approx 4,690 \text{ Hz} \\ &\text{where accel time is 25\% of total move time and starting speed is 100 Hz.} \\ &= 4,690 \text{ Hz} \times (60 \text{ sec}/1 \text{ min}) \div 400 \text{ steps/rev} \\ &\approx 703 \text{ RPM motor speed} \end{aligned}$$

Step 4 - Determine the Required Motor Torque

Using the equations in Table 1:

$$J_{\text{total}} = J_{\text{motor}} + J_{\text{gear}} + ((J_{\text{coupling}} + J_{\text{screw}} + J_{\text{W}}) \div i^2)$$

For this example, let's assume the gearbox and coupling inertia are zero.

$$\begin{aligned} J_{\text{W}} &= (W \div (g \times e)) \times (1 \div 2 \times \pi P)^2 \\ &= (200 \div (386 \times 0.9)) \times (1 \div 2 \times 3.14 \times 1.67)^2 \\ &\approx 0.0052 \text{ lb-in-sec}^2 \end{aligned}$$

$$\begin{aligned} J_{\text{screw}} &\approx (\pi \times L \times \rho \times r^4) \div (2g) \\ &\approx (3.14 \times 23.6 \times 0.28 \times 0.3^4) \div (2 \times 386) \\ &\approx 0.0002 \text{ lb-in-sec}^2 \end{aligned}$$

The inertia of the load and screw reflected to the motor is:

$$\begin{aligned} J_{\text{(screw + load) to motor}} &= ((J_{\text{screw}} + J_{\text{W}}) \div i^2) \\ &\approx ((0.0002 + 0.0052) \div 2^2) = 0.00135 \text{ lb-in-sec}^2 \end{aligned}$$

The torque required to accelerate the inertia is:

$$\begin{aligned} T_{\text{accel}} &\approx J_{\text{total}} \times (\Delta\text{speed} \div \Delta\text{time}) \times 0.1 \\ &= 0.00135 \times (603 \div 0.2) \times 0.1 \approx 0.4 \text{ lb-in} \end{aligned}$$

Next, we need to determine running torque. If the machine already exists then it is sometimes possible to actually measure running torque by turning the actuator driveshaft with a torque wrench.

$$T_{\text{run}} = ((F_{\text{total}} \div (2 \pi P)) + T_{\text{preload}}) \div i$$

$$\begin{aligned} F_{\text{total}} &= F_{\text{ext}} + F_{\text{friction}} + F_{\text{gravity}} \\ &= 0 + \mu W \cos \theta + 0 = 0.05 \times 200 = 10 \text{ lb} \end{aligned}$$

$$\begin{aligned} T_{\text{run}} &= (10 \div (2 \times 3.14 \times 1.66)) \div 2 \\ &\approx 0.48 \text{ lb-in} \end{aligned}$$

where we have assumed preload torque to be zero.

From Equation ⑤, the required motor torque is:

$$T_{\text{motor}} = T_{\text{accel}} + T_{\text{run}} = 0.4 + 0.48 \approx 0.88 \text{ lb-in}$$

However, this is the required motor torque before we have picked a motor and included the motor inertia.

Step 5 - Select and Confirm the Stepping Motor and Driver System

It looks like a reasonable choice for a motor would be the STP-MTR-23055 or shorter NEMA 23. This motor has an inertia of:

$$J_{\text{motor}} = 0.00024 \text{ lb-in-sec}^2$$

The actual motor torque would be modified:

$$\begin{aligned} T_{\text{accel}} &= J_{\text{total}} \times (\Delta\text{speed} \div \Delta\text{time}) \times 0.1 \\ &= (0.00135 + \mathbf{0.00024}) \times (603 \div 0.2) \times 0.1 \\ &\approx 0.48 \text{ lb-in} \end{aligned}$$

so that:

$$\begin{aligned} T_{\text{motor}} &= T_{\text{accel}} + T_{\text{run}} \\ &= 0.48 + 0.48 \approx 0.96 \text{ lb-in} \approx 16 \text{ oz-in} \end{aligned}$$

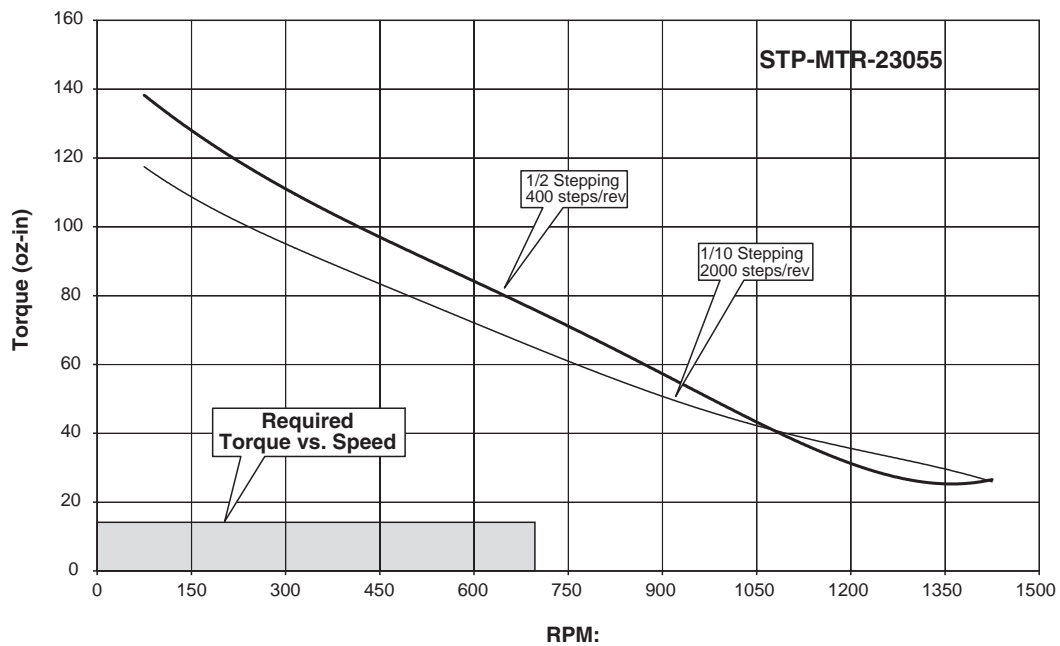

It looks like the STP-MTR-23055 stepping motor will work. However, we still need to check the load to motor inertia ratio:

$$\begin{aligned} \text{Ratio} &= J_{\text{(screw + load) to motor}} \div J_{\text{motor}} \\ &= 0.00135 \div 0.00024 = 5.625 \end{aligned}$$

It is best to keep the load to motor inertia ratio below 10 so 5.625 is within an acceptable range. For additional comfort, you could move up to the STP-MTR-23079 or the larger NEMA 23 motor. In this case, the load to motor inertia ratio would be lowered to 3.2.

Belt Drive - Example Calculations

Step 1 - Define the Actuator and Motion Requirements

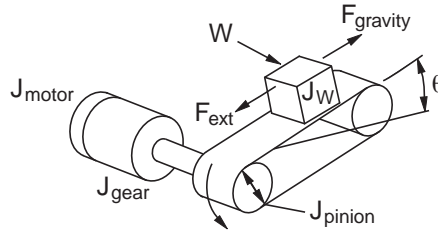

- Weight of table and workpiece = 3 lb
- External force = 0 lb
- Friction coefficient of sliding surfaces = 0.05
- Angle of table = 0°
- Belt and pulley efficiency = 0.8
- Pulley diameter = 1.5 inch
- Pulley thickness = 0.75 inch
- Pulley material = aluminum
- Desired Resolution = 0.001 inch/step
- Gear Reducer = 5:1
- Stroke = 50 inch
- Move time = 4.0 seconds
- Accel and decel time = 1.0 seconds

Definitions
d_{load} = lead or distance the load moves per revolution of the actuator's drive shaft ($P = \text{pitch} = 1/d_{load}$)
D_{total} = total move distance
θ_{step} = driver step resolution (steps/rev _{motor})
i = gear reduction ratio (rev _{motor} /rev _{gearshaft})
T_{accel} = motor torque required to accelerate and decelerate the total system inertia (including motor inertia)
T_{run} = constant motor torque requirement to run the mechanism due to friction, external load forces, etc.
t_{total} = move time

Step 2 - Determine the Positioning Resolution of the Load

Rearranging Equation ④ to calculate the required stepping drive resolution:

$$\begin{aligned} \theta_{step} &= (d_{load} \div i) \div L_{\theta} \\ &= ((3.14 \times 1.5) \div 5) \div 0.001 \\ &= 942 \text{ steps/rev} \\ &\text{where } d_{load} = \pi \times \text{Pulley Diameter.} \end{aligned}$$

With the 5:1 gear reduction, the stepping system can be set at 1000 steps/rev to slightly exceed the required load positioning resolution.

Reduction is almost always required with a belt drive and a 5:1 planetary gearhead is common.

Step 3 - Determine the Motion Profile

From **Equation ①**, the total pulses to make the required move is:

$$\begin{aligned} P_{\text{total}} &= (D_{\text{total}} \div (d_{\text{load}} \div i)) \times \theta_{\text{step}} \\ &= 50 \div ((3.14 \times 1.5) \div 5) \times 1000 \\ &\approx 53,079 \text{ pulses} \end{aligned}$$

From **Equation ④**, the running frequency for a trapezoidal move is:

$$\begin{aligned} f_{\text{TRAP}} &= (P_{\text{total}} - (f_{\text{start}} \times t_{\text{ramp}})) \div (t_{\text{total}} - t_{\text{ramp}}) \\ &= 53,079 \div (4 - 1) \\ &\approx 17,693 \text{ Hz} \end{aligned}$$

where accel time is 25% of total move time and starting speed is zero.

$$\begin{aligned} &= 17,693 \text{ Hz} \times (60 \text{ sec}/1 \text{ min}) \div 1000 \text{ steps/rev} \\ &\approx 1,062 \text{ RPM motor speed} \end{aligned}$$

Step 4 - Determine the Required Motor Torque

Using the equations in **Table 1**:

$$J_{\text{total}} = J_{\text{motor}} + J_{\text{gear}} + ((J_{\text{pulleys}} + J_{\text{W}}) \div i^2)$$

For this example, let's assume the gearbox inertia is zero.

$$\begin{aligned} J_{\text{W}} &= (W \div (g \times e)) \times r^2 \\ &= (3 \div (386 \times 0.8)) \times 0.752 \\ &\approx 0.0055 \text{ lb-in-sec}^2 \end{aligned}$$

Pulley inertia (remember there are two pulleys) can be calculated as:

$$\begin{aligned} J_{\text{pulleys}} &\approx ((\pi \times L \times \rho \times r^4) \div (2g)) \times 2 \\ &\approx ((3.14 \times 0.75 \times 0.098 \times 0.754) \div (2 \times 386)) \times 2 \\ &\approx 0.00019 \text{ lb-in-sec}^2 \end{aligned}$$

The inertia of the load and pulleys reflected to the motor is:

$$\begin{aligned} J_{(\text{pulleys} + \text{load}) \text{ to motor}} &= ((J_{\text{pulleys}} + J_{\text{W}}) \div i^2) \\ &\approx ((0.0055 + 0.00019) \div 52) \approx 0.00023 \text{ lb-in-sec}^2 \end{aligned}$$

The torque required to accelerate the inertia is:

$$\begin{aligned} T_{\text{acc}} &\approx J_{\text{total}} \times (\Delta\text{speed} \div \Delta\text{time}) \times 0.1 \\ &= 0.00023 \times (1062 \div 1) \times 0.1 \\ &= 0.025 \text{ lb-in} \end{aligned}$$

$$T_{\text{run}} = (F_{\text{total}} \times r) \div i$$

$$\begin{aligned} F_{\text{total}} &= F_{\text{ext}} + F_{\text{friction}} + F_{\text{gravity}} \\ &= 0 + \mu W \cos\theta + 0 = 0.05 \times 3 = 0.15 \text{ lb} \end{aligned}$$

$$\begin{aligned} T_{\text{run}} &= (0.15 \times 0.75) \div 5 \\ &\approx 0.0225 \text{ lb-in} \end{aligned}$$

From **Equation ⑤**, the required motor torque is:

$$T_{\text{motor}} = T_{\text{accel}} + T_{\text{run}} = 0.025 + 0.0225 \approx 0.05 \text{ lb-in}$$

However, this is the required motor torque before we have picked a motor and included the motor inertia.

Step 5 - Select and Confirm the Stepping Motor and Driver System

It looks like a reasonable choice for a motor would be the STP-MTR-17048 or NEMA 17 motor. This motor has an inertia of:

$$J_{\text{motor}} = 0.00006 \text{ lb-in-sec}^2$$

The actual motor torque would be modified:

$$\begin{aligned} T_{\text{accel}} &= J_{\text{total}} \times (\Delta\text{speed} \div \Delta\text{time}) \times 0.1 \\ &= (0.00023 + 0.00006) \times (1062 \div 1) \times 0.1 \approx 0.03 \text{ lb-in} \end{aligned}$$

so that:

$$\begin{aligned} T_{\text{motor}} &= T_{\text{accel}} + T_{\text{run}} \\ &= 0.03 + 0.0225 \approx 0.0525 \text{ lb-in} \approx 0.84 \text{ oz-in} \end{aligned}$$

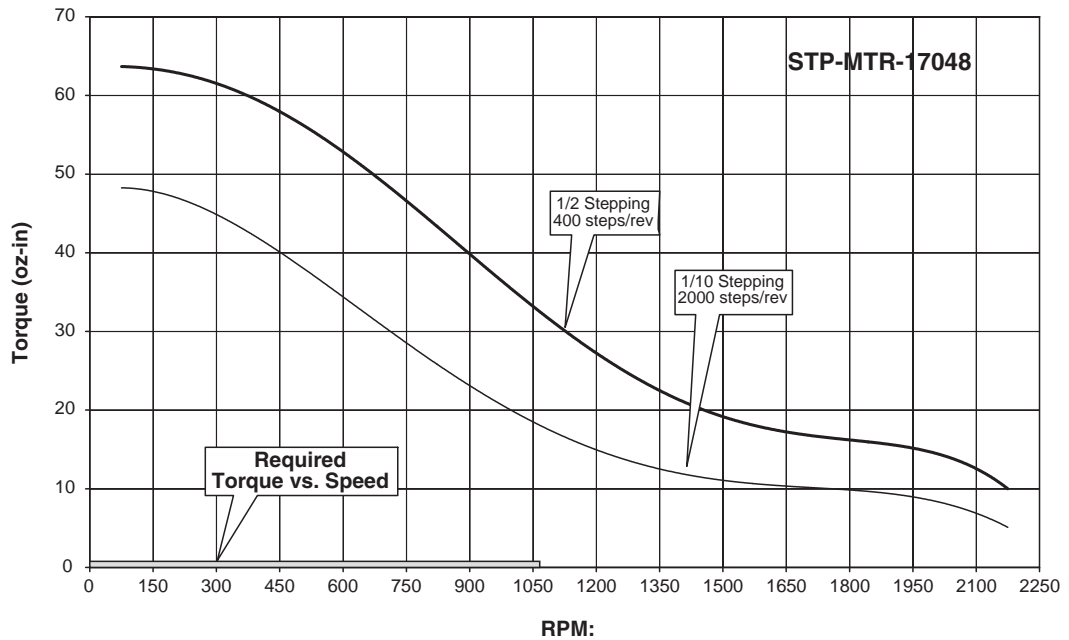

It looks like the STP-MTR-17048 stepping motor will work. However, we still need to check the load to motor inertia ratio:

$$\begin{aligned} \text{Ratio} &= J_{(\text{pulleys} + \text{load}) \text{ to motor}} \div J_{\text{motor}} \\ &= 0.00023 \div 0.00006 = 3.8 \end{aligned}$$

It is best to keep the load to motor inertia ratio below 10 so 3.8 is within an acceptable range.

Index Table - Example Calculations

Step 1 - Define the Actuator and Motion Requirements

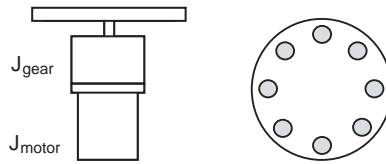

Diameter of index table = 12 inch
 Thickness of index table = 2 inch
 Table material = steel
 Number of workpieces = 8
 Desired Resolution = 0.036°
 Gear Reducer = 25:1
 Index angle = 45°
 Index time = 0.7 seconds

Definitions
d_{load} = lead or distance the load moves per revolution of the actuator's drive shaft ($P = \text{pitch} = 1/d_{load}$)
D_{total} = total move distance
θ_{step} = driver step resolution (steps/rev _{motor})
i = gear reduction ratio (rev _{motor} /rev _{gearshaft})
T_{accel} = motor torque required to accelerate and decelerate the total system inertia (including motor inertia)
T_{run} = constant motor torque requirement to run the mechanism due to friction, external load forces, etc.
t_{total} = move time

Step 2 - Determine the Positioning Resolution of the Load

Rearranging **Equation ④** to calculate the required stepping drive resolution:

$$\begin{aligned} \theta_{step} &= (d_{load} \div i) \div L_{\theta} \\ &= (360^\circ \div 25) \div 0.036^\circ \\ &= 400 \text{ steps/rev} \end{aligned}$$

With the 25:1 gear reduction, the stepping system can be set at 400 steps/rev to equal the required load positioning resolution.

It is almost always necessary to use significant gear reduction when controlling a large inertia disk.

Step 3 - Determine the Motion Profile

From Equation ①, the total pulses to make the required move is:

$$\begin{aligned} P_{\text{total}} &= (D_{\text{total}} \div (d_{\text{load}} \div i)) \times \theta_{\text{step}} \\ &= (45^\circ \div (360^\circ \div 25)) \times 400 \\ &= 1250 \text{ pulses} \end{aligned}$$

From Equation ④, the running frequency for a trapezoidal move is:

$$\begin{aligned} f_{\text{TRAP}} &= (P_{\text{total}} - (f_{\text{start}} \times t_{\text{ramp}})) \div (t_{\text{total}} - t_{\text{ramp}}) \\ &= 1,250 \div (0.7 - 0.17) \approx 2,360 \text{ Hz} \\ &\text{where accel time is 25\% of total move time and starting speed is zero.} \\ &= 2,360 \text{ Hz} \times (60 \text{ sec}/1 \text{ min}) \div 400 \text{ steps/rev} \\ &\approx 354 \text{ RPM} \end{aligned}$$

Step 4 - Determine the Required Motor Torque

Using the equations in Table 1:

$$J_{\text{total}} = J_{\text{motor}} + J_{\text{gear}} + (J_{\text{table}} \div i^2)$$

For this example, let's assume the gearbox inertia is zero.

$$\begin{aligned} J_{\text{table}} &\approx (\pi \times L \times \rho \times r^4) \div (2g) \\ &\approx (3.14 \times 2 \times 0.28 \times 1296) \div (2 \times 386) \\ &\approx 2.95 \text{ lb-in-sec}^2 \end{aligned}$$

The inertia of the indexing table reflected to the motor is:

$$\begin{aligned} J_{\text{table to motor}} &= J_{\text{table}} \div i^2 \\ &\approx 0.0047 \text{ lb-in-sec}^2 \end{aligned}$$

The torque required to accelerate the inertia is:

$$\begin{aligned} T_{\text{accel}} &\approx J_{\text{total}} \times (\Delta\text{speed} \div \Delta\text{time}) \times 0.1 \\ &= 0.0047 \times (354 \div 0.17) \times 0.1 \\ &\approx 1.0 \text{ lb-in} \end{aligned}$$

From Equation ⑤, the required motor torque is:

$$\begin{aligned} T_{\text{motor}} &= T_{\text{accel}} + T_{\text{run}} \\ &= 1.0 + 0 = 1.0 \text{ lb-in} \end{aligned}$$

However, this is the required motor torque before we have picked a motor and included the motor inertia.

Step 5 - Select and Confirm the Stepping Motor and Driver System

It looks like a reasonable choice for a motor would be the STP-MTR-34066 or NEMA 34 motor. This motor has an inertia of:

$$J_{\text{motor}} = 0.0012 \text{ lb-in-sec}^2$$

The actual motor torque would be modified:

$$\begin{aligned} T_{\text{accel}} &= J_{\text{total}} \times (\Delta\text{speed} \div \Delta\text{time}) \times 0.1 \\ &= (0.0047 + \mathbf{0.0012}) \times (354 \div 0.17) \times 0.1 \\ &\approx 1.22 \text{ lb-in} \end{aligned}$$

so that:

$$\begin{aligned} T_{\text{motor}} &= T_{\text{accel}} + T_{\text{run}} \\ &= 1.22 + 0 \\ &= 1.22 \text{ lb-in} = 19.52 \text{ oz-in} \end{aligned}$$

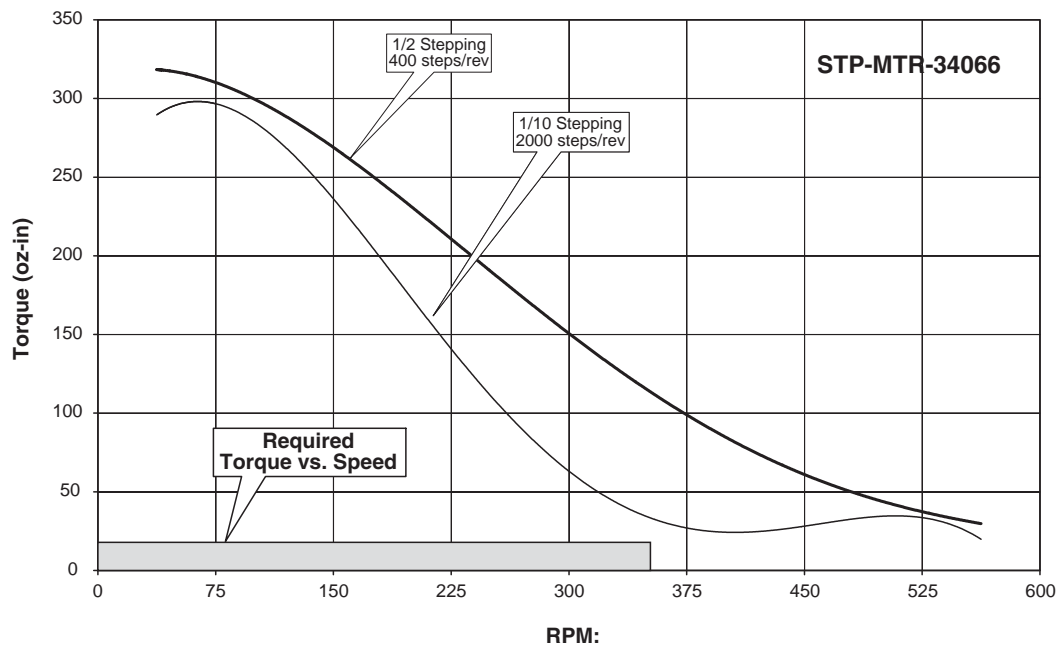

It looks like the STP-MTR-34066 stepping motor will work. However, we still need to check the load to motor inertia ratio:

$$\begin{aligned} \text{Ratio} &= J_{\text{table to motor}} \div J_{\text{motor}} \\ &= 0.0047 \div 0.0012 = 3.9 \end{aligned}$$

It is best to keep the load to motor inertia ratio below 10 so 3.9 is within an acceptable range.

Engineering Unit Conversion Tables, Formulae, & Definitions:

Conversion of Length							
To convert A to B, multiply A by the entry in the table.		B					
		µm	mm	m	mil	in	ft
A	µm	1	1.000E-03	1.000E-06	3.937E-02	3.937E-05	3.281E-06
	mm	1.000E+03	1	1.000E-03	3.937E+01	3.937E-02	3.281E-03
	m	1.000E+06	1.000E+03	1	3.937E+04	3.937E+01	3.281E+00
	mil	2.540E+01	2.540E-02	2.540E-05	1	1.000E-03	8.330E-05
	in	2.540E+04	2.540E+01	2.540E-02	1.000E+03	1	8.330E-02
	ft	3.048E+05	3.048E+02	3.048E-01	1.200E+04	1.200E+01	1

Conversion of Torque							
To convert A to B, multiply A by the entry in the table.		B					
		Nm	kpm(kg-m)	kg-cm	oz-in	lb-in	lb-ft
A	Nm	1	1.020E-01	1.020E+01	1.416E+02	8.850E+00	7.380E-01
	kpm(kg-m)	9.810E+00	1	1.000E+02	1.390E+03	8.680E+01	7.230E+00
	kg-cm	9.810E-02	1.000E-02	1	1.390E+01	8.680E-01	7.230E-02
	oz-in	7.060E-03	7.200E-04	7.200E-02	1	6.250E-02	5.200E-03
	lb-in	1.130E-01	1.150E-02	1.150E+00	1.600E+01	1	8.330E-02
	lb-ft	1.356E+00	1.380E-01	1.383E+01	1.920E+02	1.200E+01	1

Conversion of Moment of Inertia								
To convert A to B, multiply A by the entry in the table.		B						
		kg-m ²	kg-cm-s ²	oz-in-s ²	lb-in-s ²	oz-in ²	lb-in ²	lb-ft ²
A	kg-m ²	1	1.020E+01	1.416E+02	8.850E+00	5.470E+04	3.420E+03	2.373E+01
	kg-cm-s ²	9.800E-02	1	1.388E+01	8.680E-01	5.360E+03	3.350E+02	2.320E+00
	oz-in-s ²	7.060E-03	7.190E-02	1	6.250E-02	3.861E+02	2.413E+01	1.676E-01
	lb-in-s ²	1.130E-01	1.152E+00	1.600E+01	1	6.180E+03	3.861E+02	2.681E+00
	oz-in ²	1.830E-05	1.870E-04	2.590E-03	1.620E-04	1	6.250E-02	4.340E-04
	lb-in ²	2.930E-04	2.985E-03	4.140E-02	2.590E-03	1.600E+01	1	6.940E-03
	lb-ft ²	4.210E-02	4.290E-01	5.968E+00	3.730E-01	2.304E+03	1.440E+02	1

Engineering Unit Conversion Tables, Formulae, & Definitions (cont'd):

General Formulae & Definitions	
Description:	Equations:
Gravity	gravity = 9.8 m/s ² ; 386 in/s ²
Torque	$T = J \cdot \alpha$; $\alpha = \text{rad/s}^2$
Power (Watts)	$P (W) = T (N \cdot m) \cdot \omega (\text{rad/s})$
Power (Horsepower)	$P (hp) = T (\text{lb} \cdot \text{in}) \cdot \nu (\text{rpm}) / 63,024$
Horsepower	1 hp = 746W
Revolutions	1 rev = 1,296,000 arc-sec / 21,600 arc-min

Equations for Straight-Line Velocity & Constant Acceleration	
Description:	Equations:
Final velocity	$v_f = v_i + at$ final velocity = (initial velocity) + (acceleration)(time)
Final position	$x_f = x_i + \frac{1}{2}(v_i + v_f)t$ final position = initial position + [(1/2)(initial velocity + final velocity)(time)]
Final position	$x_f = x_i + v_i t + \frac{1}{2}at^2$ final position = initial position + (initial velocity)(time) + (1/2)(acceleration)(time squared)
Final velocity squared	$v_f^2 = v_i^2 + 2a(x_f - x_i)$ final velocity squared = initial velocity squared + [(2)(acceleration)(final position - initial position)]

USING
SureStep[™] WITH
*DIRECT*LOGIC PLCs



APPENDIX
B

In This Appendix...

Compatible <i>Direct</i> LOGIC PLCs and Modules	B-2
Typical Connections to a DL05 PLC	B-4
Typical Connections to an H0-CTRIO	B-5
Typical Connections – Multiple Drive/Motors	B-6
Typical PLC Serial Connections to an Advanced <i>SureStep</i> Drive	B-7

Compatible DirectLOGIC PLCs and Modules

The following tables show which high-speed pulse-output DirectLOGIC PLCs and modules can be used with the SureStep Microstepping Motor Drives.

<i>DirectLOGIC PLCs/Modules for Use with SureStep Drive (1)</i>	
DL05 PLCs	
D0-05AD	DL05 CPU, 8 AC in / 6 DC out, 110/220 VAC power supply. <u>Inputs:</u> 8 AC inputs, 90-120 VAC, 2 isolated commons. <u>Outputs:</u> 6 DC outputs, 6-27 VDC current sinking, 1.0 A/pt max, 1 common. Two outputs are configurable for independent CW/CCW pulse train output or step and direction pulse output up to 7kHz (0.5 A/pt.).
D0-05DD	DL05 CPU, 8 DC in / 6 DC out, 110/220 VAC power supply. <u>Inputs:</u> 8 DC inputs, 12-24 VDC current sinking/sourcing, 2 isolated commons. <u>Outputs:</u> 6 DC outputs, 6-27 VDC current sinking, 1.0 A/pt max, 1 common. Two outputs are configurable for independent CW/CCW pulse train output or step and direction pulse output up to 7kHz (0.5 A/pt) (not available when using high-speed inputs).
D0-05DD-D	DL05 CPU, 8 DC in / 6 DC out, 12/24 VDC power supply. <u>Inputs:</u> 8 DC inputs, 12-24 VDC current sinking/sourcing, 2 isolated commons. <u>Outputs:</u> 6 DC outputs, 6-27 VDC current sinking, 1.0 A/pt max, 1 common. Two outputs are configurable for independent CW/CCW pulse train output or step and direction pulse output up to 7kHz (0.5 A/pt.) (not available when using high-speed inputs).
DL06 PLCs	
D0-06DD1	DL06 CPU, 20 DC in / 16 DC out, 110/220 VAC power supply, with 0.3A 24 VDC auxiliary device power supply. <u>Inputs:</u> 20 DC inputs, 12-24 VDC current sinking/sourcing, 5 isolated commons (4 inputs per common). <u>Outputs:</u> 16 DC outputs, 12-24 VDC current sinking, 1.0A/pt max, 4 commons non-isolated (4 points per common). Two outputs are configurable for independent CW/CCW pulse train output or step and direction pulse output up to 10 kHz (0.5 A/pt) (not available when using high-speed inputs).
D0-06DD2	DL06 CPU, 20 DC in / 16 DC out, 110/220 VAC power supply, with 0.3A 24 VDC auxiliary device power supply. <u>Inputs:</u> 20 DC inputs, 12-24 VDC current sinking/sourcing, 5 isolated commons (4 inputs per common). <u>Outputs:</u> 16 DC outputs, 12-24 VDC current sourcing 1.0A/pt max, 4 commons non-isolated (4 points per common). Two outputs are configurable for independent CW/CCW pulse train output or step and direction pulse output up to 10 kHz (0.5 A/pt) (not available when using high-speed inputs).
D0-06DD1-D	DL06 CPU, 20 DC in / 16 DC out, 12/24 VDC power supply. <u>Inputs:</u> 20 DC inputs, 12-24 VDC current sinking/sourcing, 5 isolated commons (4 inputs per common). <u>Outputs:</u> 16 DC outputs, 12-24 VDC current sinking, 1.0 A/pt max, 4 commons non-isolated (4 pts/common). Two outputs are configurable for independent CW/CCW pulse train output or step and direction pulse output up to 10 kHz (0.5 A/pt) (not available when using high-speed inputs).
D0-06DD2-D	DL06 CPU, 20 DC in / 16 DC out, 12/24 VDC power supply. <u>Inputs:</u> 20 DC inputs, 12-24 VDC current sinking/sourcing, 5 isolated commons (4 inputs per common). <u>Outputs:</u> 16 DC outputs, 12-24VDC current sourcing, 1.0A/pt max, 4 commons non-isolated (4 pts/common). Two outputs are configurable for independent CW/CCW pulse train output or step and direction pulse output up to 10 kHz (0.5 A/pt) (not available when using high-speed inputs).
DL05/DL06 High Speed Counter I/O Module	
H0-CTRIO	DL05/06 High Speed Counter I/O Interface Module, 4 DC sink/source inputs 9-30 VDC, 2 isolated sink/source DC outputs, 5-30 VDC, 1A per point. <u>Inputs supported:</u> 1 quadrature encoder counters up to 100 kHz, or 2 single channel counters up to 100 kHz, and 2 high speed discrete inputs for Reset, Inhibit, or Capture. <u>Outputs supported:</u> 2 independently configurable high speed discrete outputs or 1 channel pulse output control, 20Hz-25kHz per channel, pulse and direction or CW/CCW pulses.
<i>Table continued next page.</i>	

DirectLOGIC PLCs/Modules for Use with SureStep Drive ⁽¹⁾ (continued)	
DL105 PLCs	
F1-130AD	DL130 CPU, 10 AC in / 8 DC out, 110/220 VAC power supply. <u>Inputs:</u> 10 AC inputs, 80-132 VAC, 3 isolated commons. <u>Outputs:</u> 8 DC outputs, 5-30 VDC current sinking, 0.5A/pt max, 3 internally connected commons. Two outputs are configurable for independent CW/CCW pulse train output or step and direction pulse output up to 7kHz (@ 0.25 A/pt max).
F1-130DD	DL130 CPU, 10 DC in / 8 DC out, 110/220 VAC power supply. <u>Inputs:</u> 10 DC inputs, 12-24 VDC current sinking/sourcing, 3 isolated commons. <u>Outputs:</u> 8 DC outputs, 5-30 VDC current sinking, 0.5 A/pt max, 3 internally connected commons. Two outputs are configurable for independent CW/CCW pulse train output or step and direction pulse output up to 7kHz (@ 0.25 A/pt max) (not available when using high-speed inputs).
F1-130DD-D	DL130 CPU, 10 DC in / 8 DC out, 12/24 VDC power supply. <u>Inputs:</u> 10 DC inputs, 12-24 VDC current sinking/sourcing, 3 isolated commons. <u>Outputs:</u> 8 DC outputs, 5-30 VDC current sinking, 0.5 A/pt max, 3 internally connected commons. Two outputs are configurable for independent CW/CCW pulse train output or step and direction pulse output up to 7kHz (@ 0.25 A/pt max) (not available when using high-speed inputs).
DL205 High Speed Counter I/O Modules	
H2-CTRIO⁽²⁾	DL205 High Speed Counter I/O Interface Module, 8 DC sink/source inputs 9-30 VDC, 4 isolated sink/source DC outputs, 5-30 VDC, 1A per point. <u>Inputs supported:</u> 2 quadrature encoder counters up to 100 kHz, or 4 single channel counters up to 100 kHz, and 4 high speed discrete inputs for Reset, Inhibit, or Capture. <u>Outputs supported:</u> 4 independently configurable high speed discrete outputs or 2 channels pulse output control, 20 Hz - 25 kHz per channel, pulse and direction or CW/CCW pulses.
D2-CTRINT	Counter Interface Module, 4 isolated DC inputs, 1 pulse train output (CW) or 2 pulse train outputs (CW/CCW) with DC input restrictions, accepts two up-counters when used with D2-240 or D2-250(-1) (one only with D2-230), or one up/down counter. (not available when using high-speed inputs).
Terminator I/O High Speed Counter I/O Module	
T1H-CTRIO⁽²⁾	Terminator I/O High Speed Counter I/O Interface Module, 8 DC sink/source inputs 9-30 VDC, 4 isolated sink/source DC outputs, 5-30 VDC, 1A per point. <u>Inputs supported:</u> 2 quadrature encoder counters up to 100 kHz, or 4 single channel counters up to 100 kHz, and 4 high speed discrete inputs for Reset, Inhibit, or Capture. <u>Outputs supported:</u> 4 independently configurable high speed discrete outputs or 2 channels pulse output control, 20 Hz - 25 kHz per channel, pulse and direction or CW/CCW pulses. (Use with T1K-16B or T1K-16B-1 terminal base.)
DL405 High Speed Counter I/O Module	
H4-CTRIO	DL405 High Speed Counter I/O Interface Module, 8 DC sink/source inputs 9-30 VDC, 4 isolated sink/source DC outputs, 5-30 VDC, 1A per point. <u>Inputs supported:</u> 2 quadrature encoder counters up to 100 kHz, or 4 single channel counters up to 100 kHz, and 4 high speed discrete inputs for Reset, Inhibit, or Capture. <u>Outputs supported:</u> 4 independently configurable high speed discrete outputs or 2 channels pulse output control, 20 Hz - 25 kHz per channel, pulse and direction or CW/CCW pulses.
<p>(1) Any DirectLOGIC PLC capable of RS-232 ASCII communication can write serial commands to the SureStep Advanced Microstepping Drives (STP-DRV-4850 & -80100). These PLCs include DL 05, 06, 250-1, 260, 350, and 450. However, we strongly recommend using DL06 or DL260 PLCs for serial commands due to their more advanced ASCII instruction set which includes PRINTV and VPRINT commands.</p> <p>(2) The H2-CTRIO and T1H-CTRIO High Speed Counter I/O Interface Modules can also be used to control the SureStep Stepping System in PC-Based Control systems with Think & Do/Studio, or with our embedded WinPLC/EBC module plugged into the CPU slot of the DL205 base.</p>	

Typical Connections to a DL05 PLC

The following wiring diagram shows typical connections between the SureStep Stepping System components and a DirectLOGIC DL05 PLC. Refer to the DL05 Micro PLC User Manual, p/n D0-USER-M, High-Speed Input and Pulse Output Features chapter, for detailed programming instructions when using the PLC for the Mode 30: Pulse Output function.

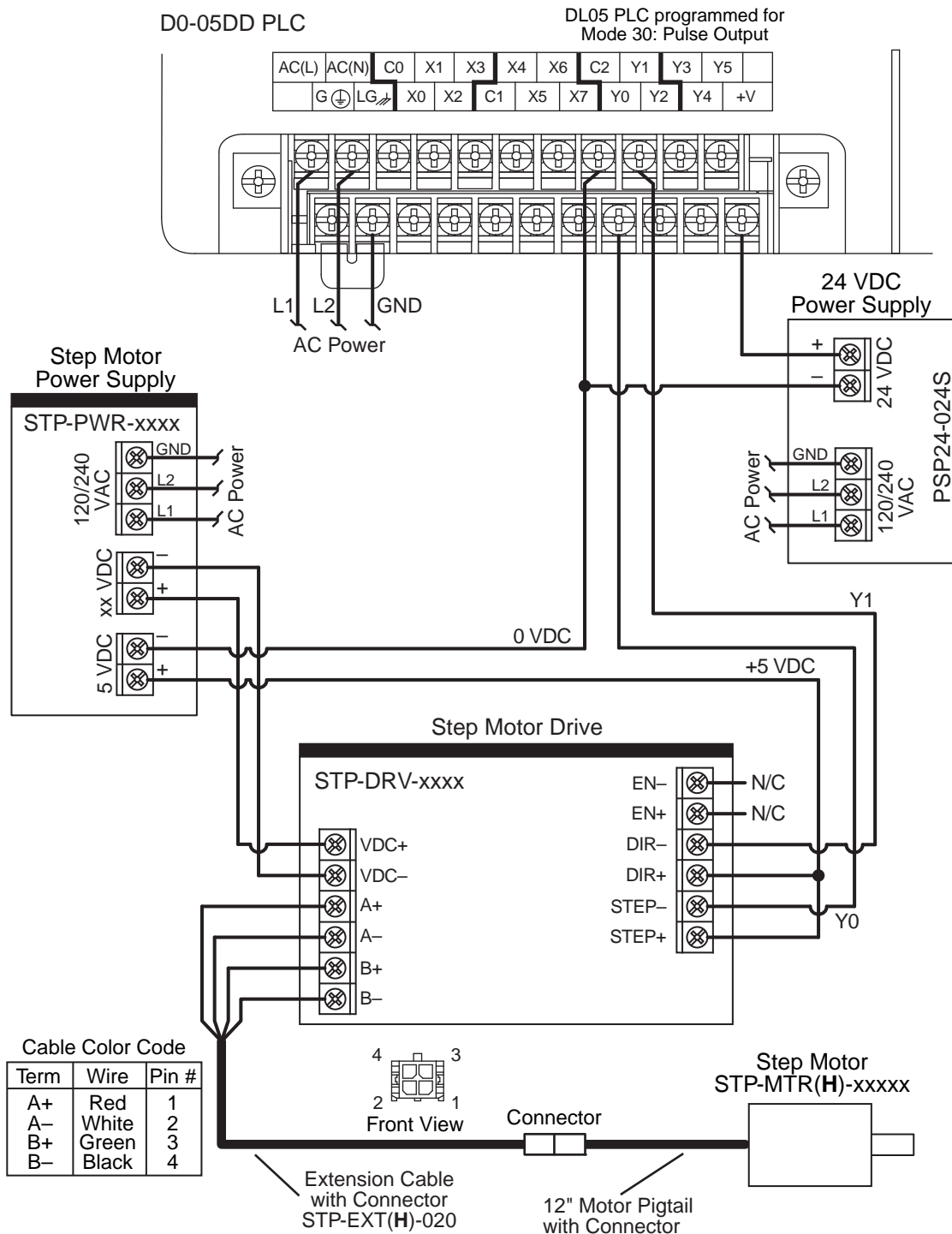

Typical Connections to an H0-CTRIO

The following wiring diagram shows typical connections between the SureStep Stepping System components and a DirectLOGIC H0-CTRIO High Speed Counter I/O Interface Module installed in either a DL05 or DL06 PLC option slot. Refer to the CTRIO High-Speed Counter Module User Manual, p/n Hx-CTRIO-M, for detailed programming instructions when using the H0-CTRIO module.

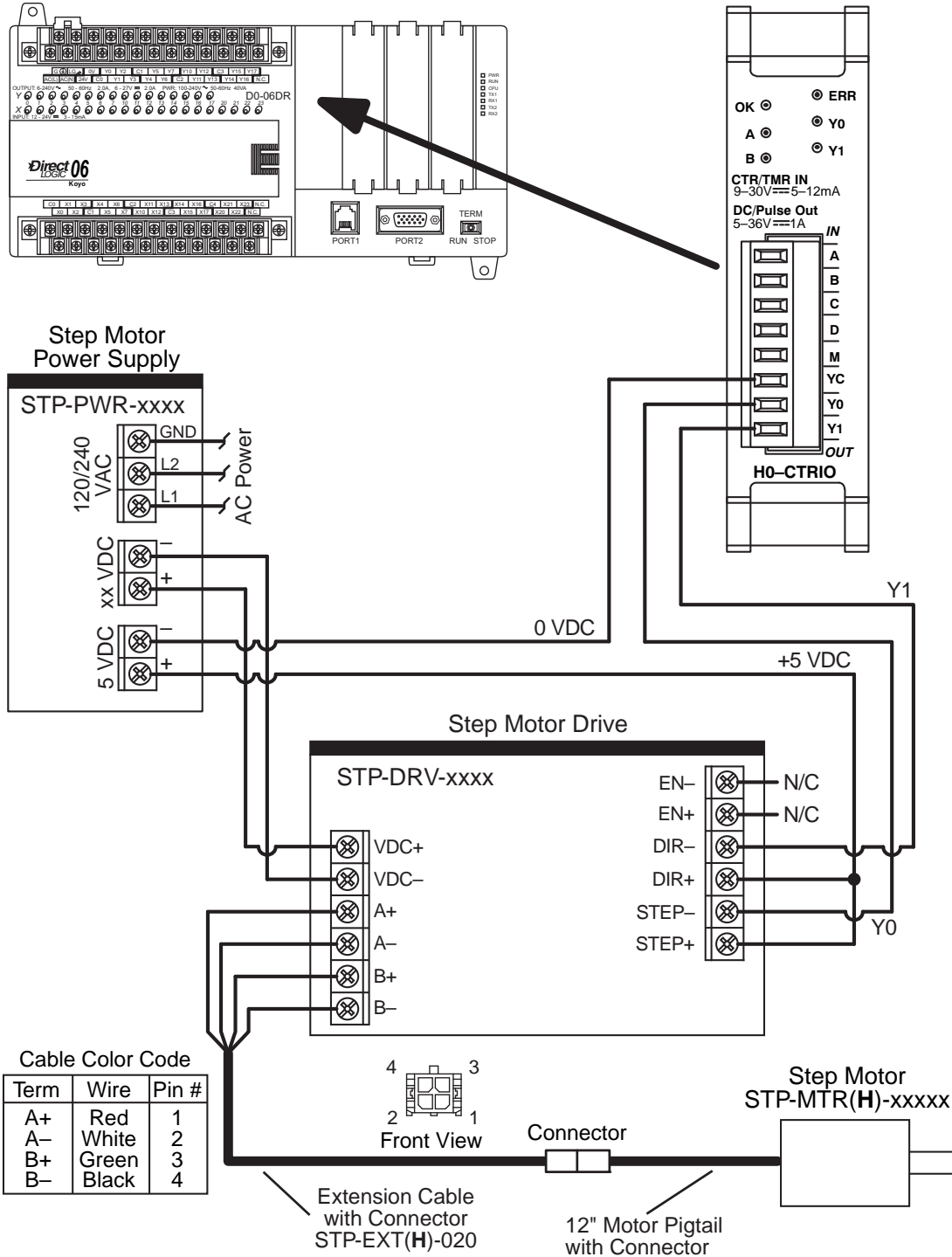

Typical Connections – Multiple Drive/Motors

The following wiring diagram shows typical connections between the SureStep Stepping System components and a DirectLOGIC H2-CTRIO High Speed Counter I/O Interface Module installed in a DL205 PLC. Refer to the CTRIO High-Speed Counter Module User Manual, p/n Hx-CTRIO-M, for detailed programming instructions when using the H2-CTRIO module.

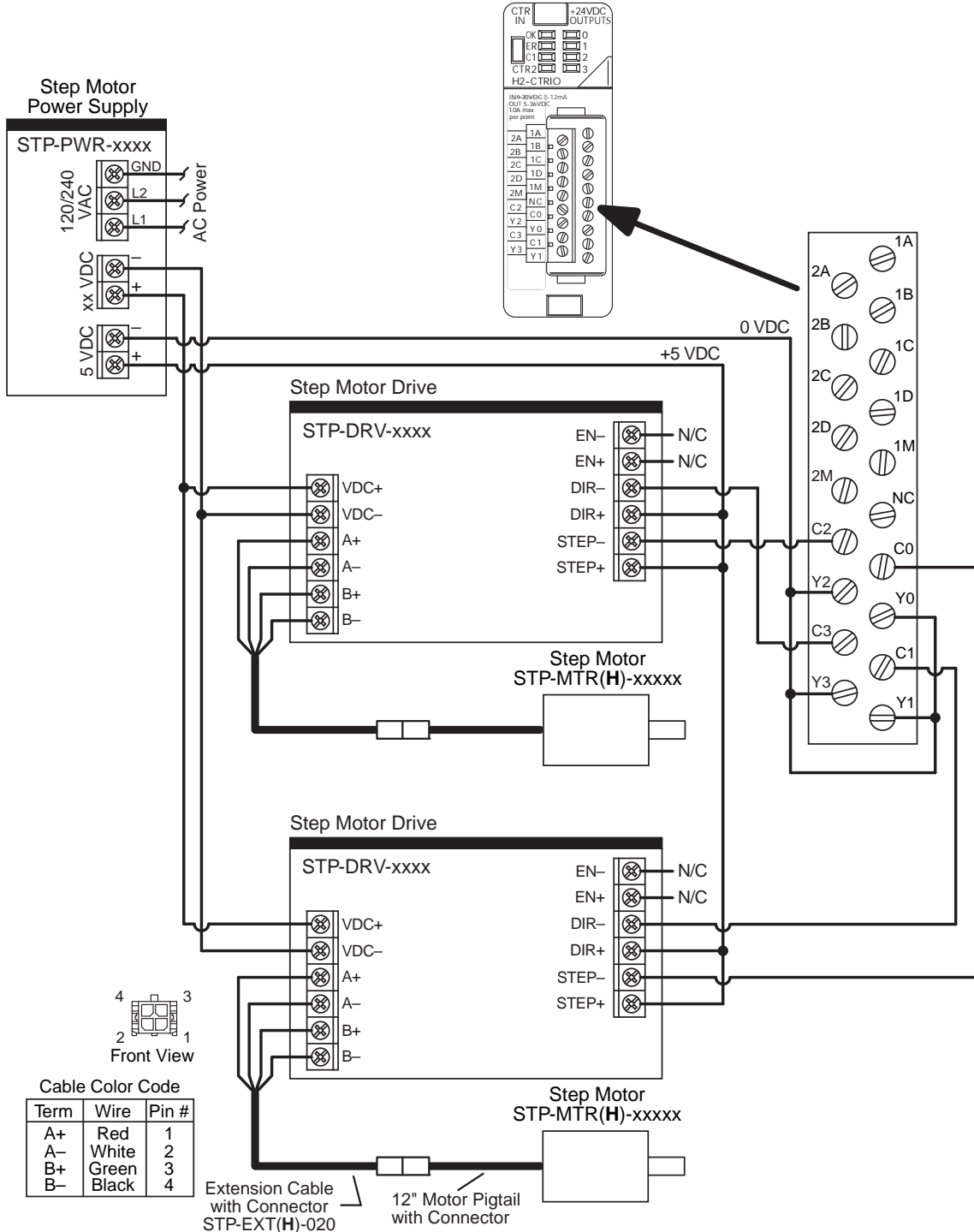

Typical PLC Serial Connections to an Advanced SureStep Drive

The following wiring diagrams show typical serial connections between a SureStep Advanced Microstepping Drive and a DirectLOGIC PLC capable of RS-232 ASCII communication. Refer to the particular PLC user manual for instructions for writing ASCII serial commands.

Serial Connection Using Automation Direct Cables

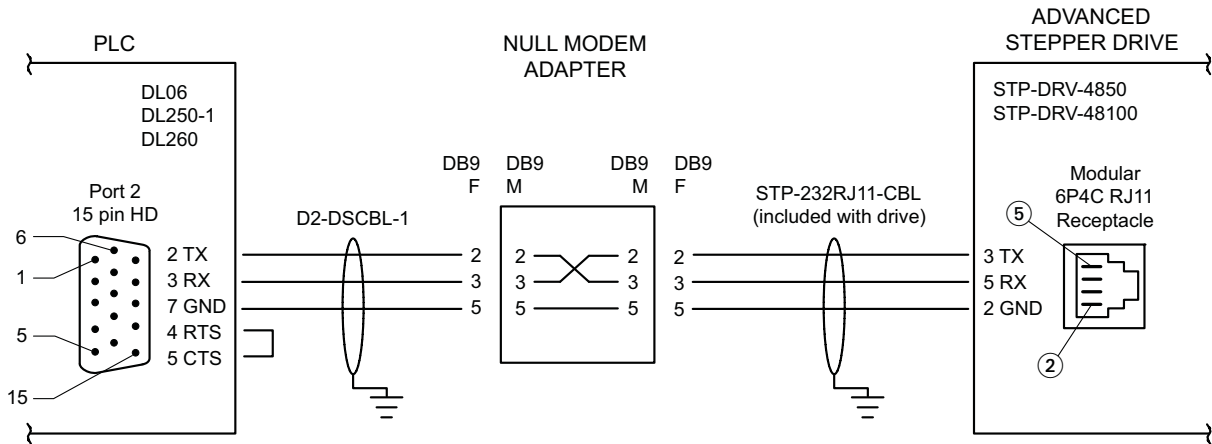

Serial Connection Using Custom Cables

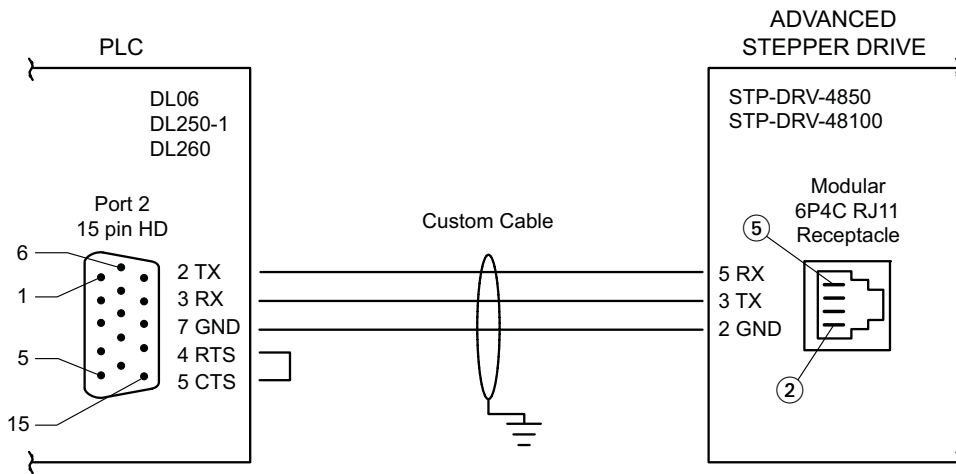

THIS PAGE
INTENTIONALLY
LEFT BLANK

THIS PAGE
INTENTIONALLY
LEFT BLANK