

2

1

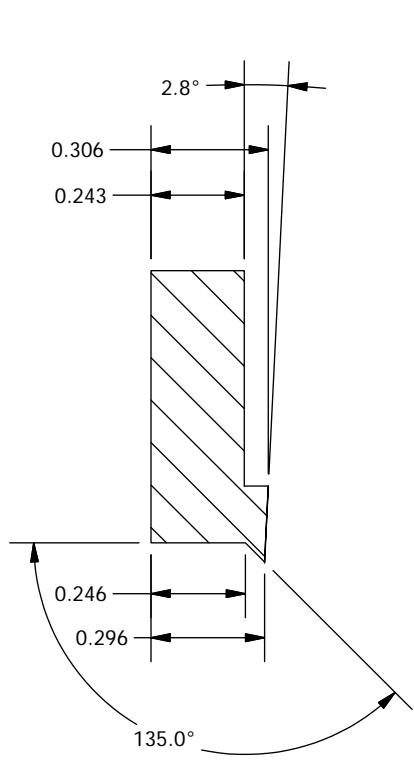

DETAIL B
SCALE 2 : 1

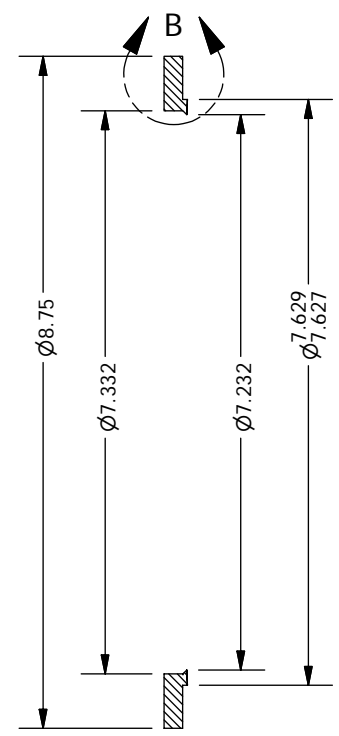
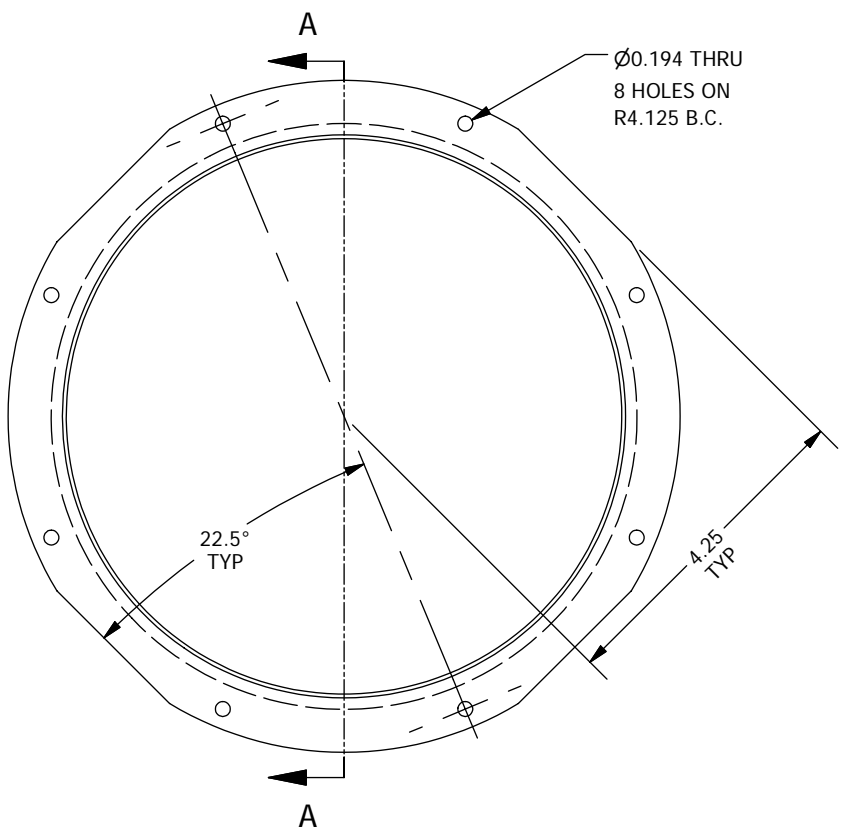

SECTION A-A
SCALE 0.40 : 1

NOTES

- 1. Anodize black after test fitting

ITEM	QTY	DESCRIPTION
1	1	PFS09014
Bill of Material		

THE OBSERVATORIES OF THE CARNEGIE INSTITUTION OF WASHINGTON 813 Santa Barbara Street Pasadena, CA 91101					
MATERIAL		UNLESS OTHERWISE SPECIFIED			
Aluminum-6061		FRACTIONAL	DECIMAL	ANGULAR	
		+/- 1/32	.XX +/- 0.01	+/- 0.1 DEG	
EST WEIGHT		.XXX +/- 0.002 GOAL			
0.2 lb		.XXX +/- 0.005 REQD			
SCALE		BREAK SHARP EDGES MACHINED SURFACES 125			
4:10		ALL DIMENSIONS IN INCHES			
			P lanet F nder S pectrograph		PFSG Axial Preload Ring
DWN	CRANE	4/25/2006		SHEET	DRAWING NUMBER
APVD				A	PFS09014
BY	DATE			SHT 1 OF 1	REV 1

2

1