

PFS08007

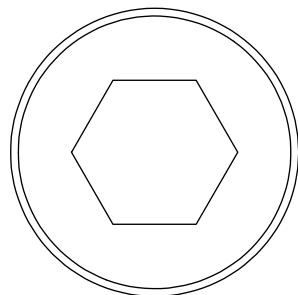

PFS08008

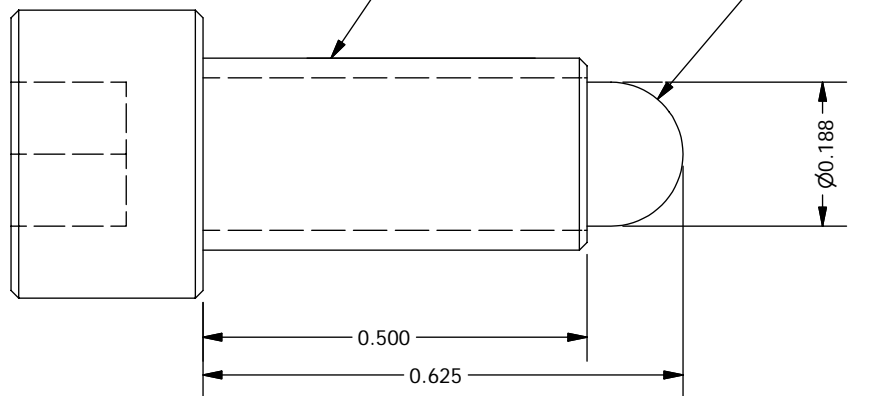
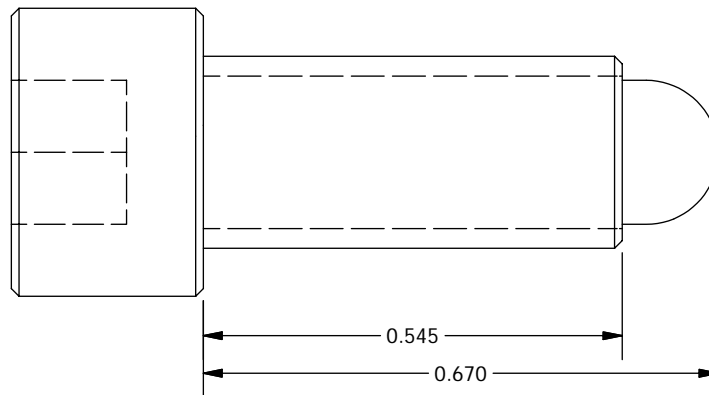

NOTES

1. Make from stainless steel socket head cap screws

THE OBSERVATORIES
OF THE CARNEGIE INSTITUTION OF WASHINGTON
813 Santa Barbara Street
Pasadena, CA 91101

MATERIAL		Stainless Steel, Austenitic		UNLESS OTHERWISE SPECIFIED	
EST WEIGHT		0.2 oz		FRACTIONAL	DECIMAL
SCALE		4:1		+/- 1/32	.XX +/- 0.01
DWN		CRANE	10/27/2009	.XXX +/- 0.002 GOAL	ANGULAR
APVD				.XXX +/- 0.005 REQD	+/- 0.1 DEG
BY		DATE		BREAK SHARP EDGES MACHINED SURFACES 125 $\sqrt{\hspace{1cm}}$	
SHEET		DRAWING NUMBER		ALL DIMENSIONS IN INCHES	
A	PFS08007-8		SHT 1	REV	
Bill of Material				OF 1	2

2	2	PFS08008
1	1	PFS08007
ITEM	QTY	DESCRIPTION
Bill of Material		

2

1

2

1