

4

3

2

1

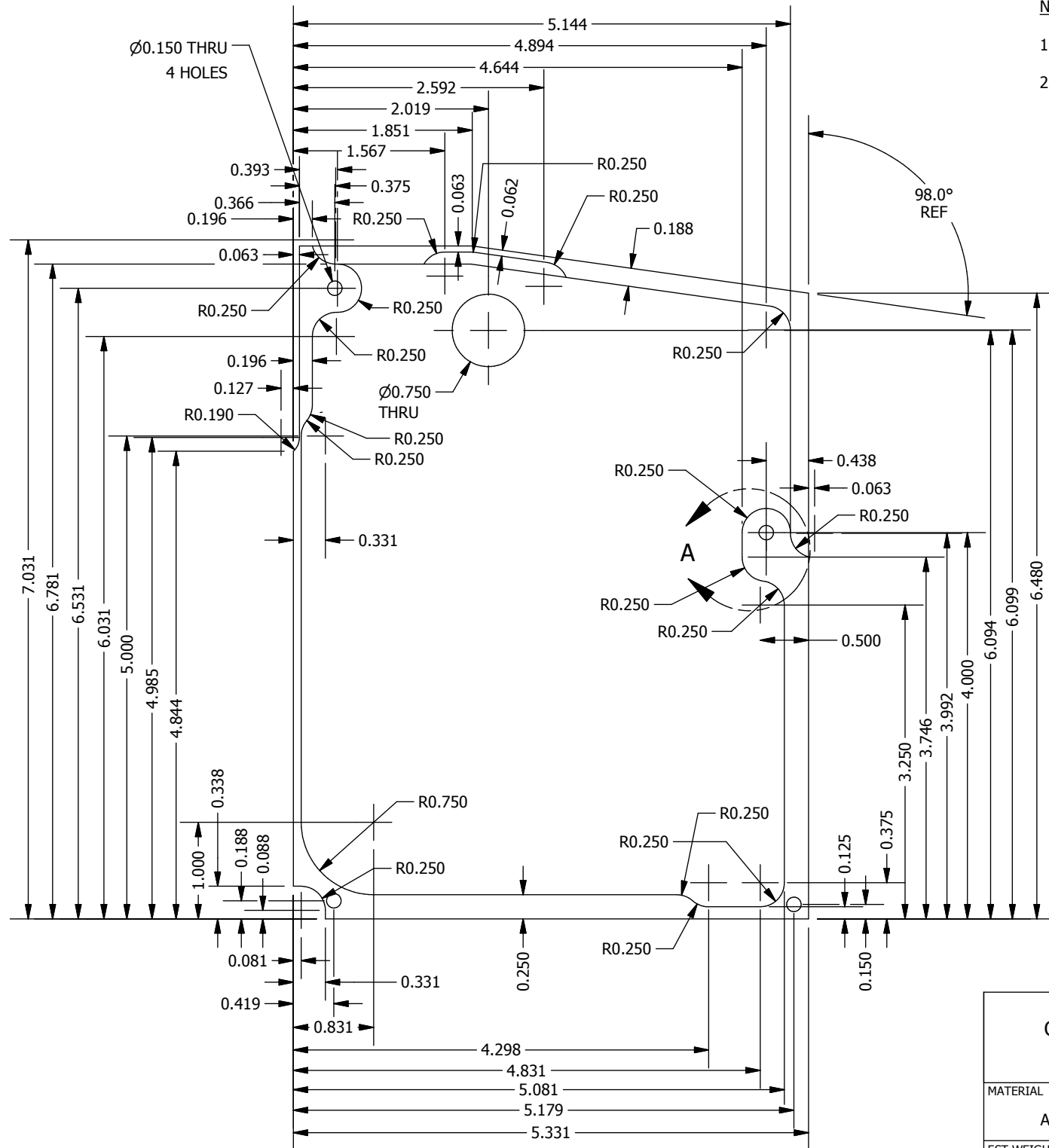
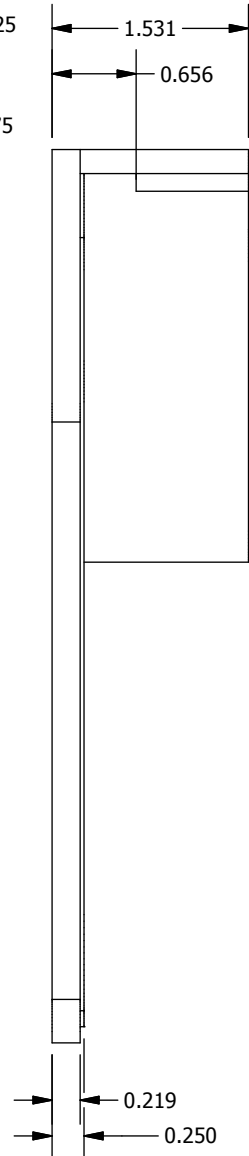
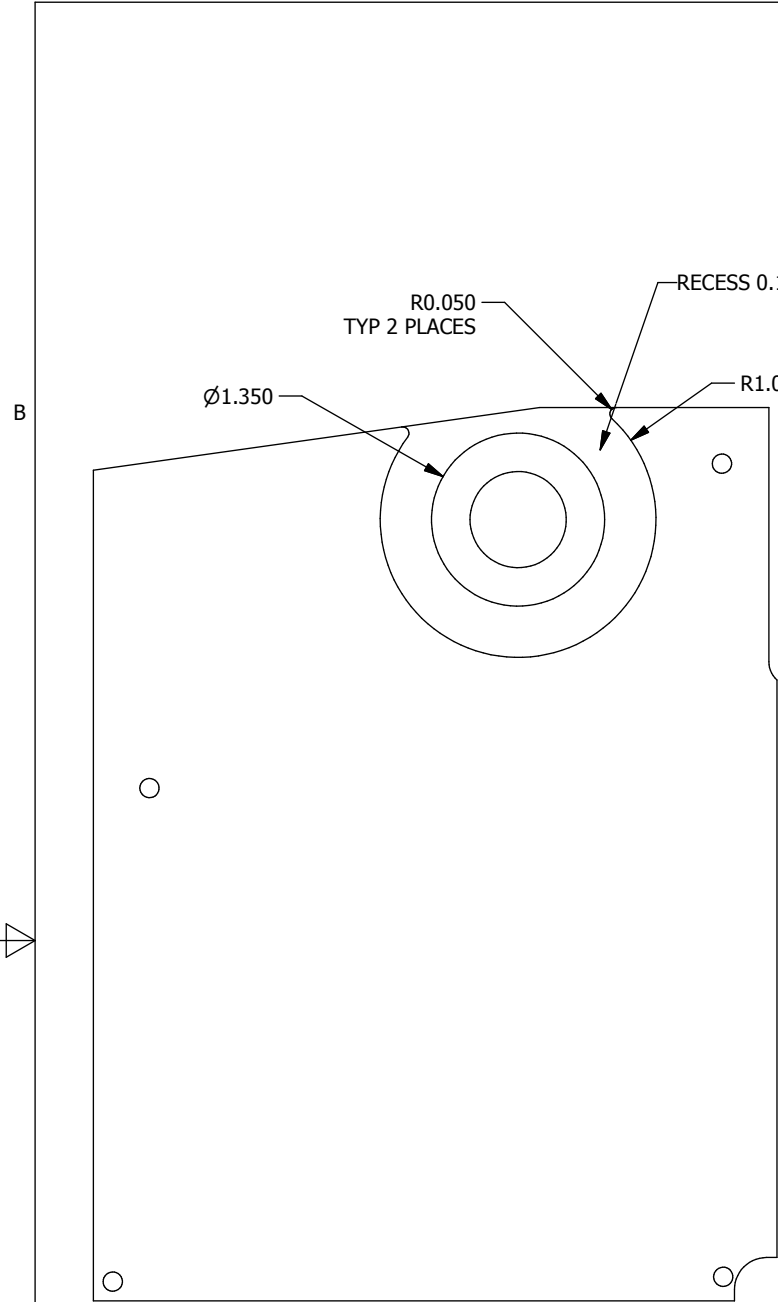

NOTES

- 1. Anodize black
- 2. Part should tightly to Slit Assembly Main Plate - 10K (PFS06024)

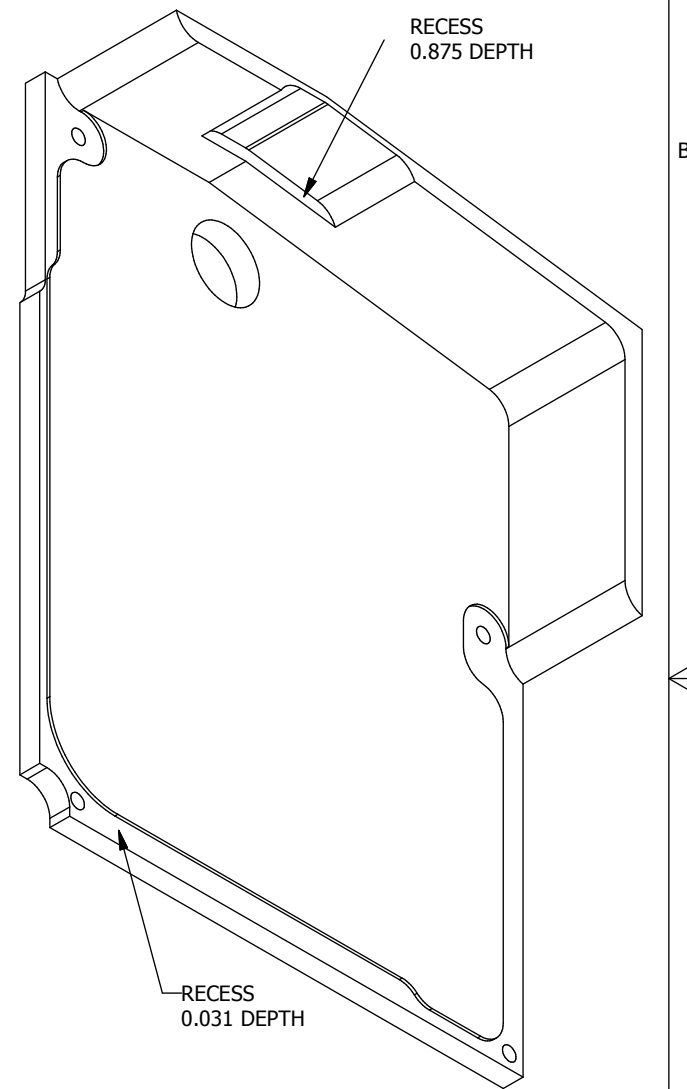

A

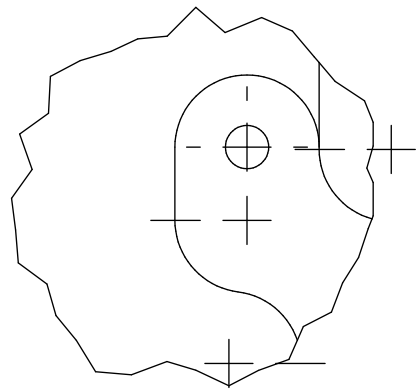

DETAIL A  
SCALE 1.50 : 1

<b>THE OBSERVATORIES OF THE CARNEGIE INSTITUTION OF WASHINGTON</b> 813 Santa Barbara Street Pasadena, CA 91101			
MATERIAL	UNLESS OTHERWISE SPECIFIED		
Aluminum-6061	FRACTIONAL +/- 1/32	DECIMAL .XX +/- 0.01 .XXX +/- 0.002 GOAL .XXX +/- 0.005 REQD	
EST WEIGHT	ANGULAR +/- 0.1 DEG		
1.0 lb	BREAK SHARP EDGES MACHINED SURFACES 125		
SCALE	ALL DIMENSIONS IN INCHES		
2:3	<b>P</b> lanet	<b>Slit Assembly Cover</b>	
	<b>F</b> nder		
	<b>S</b> pectrograph		
DWN	CRANE	10/30/2017	
APVD	BY	DATE	
SHEET	DRAWING NUMBER	SHT 1	REV
B	PFS06025	OF 1	

1	1	PFS06025
ITEM	QTY	DESCRIPTION
Bill of Material		

4

3

2

1