

2

1

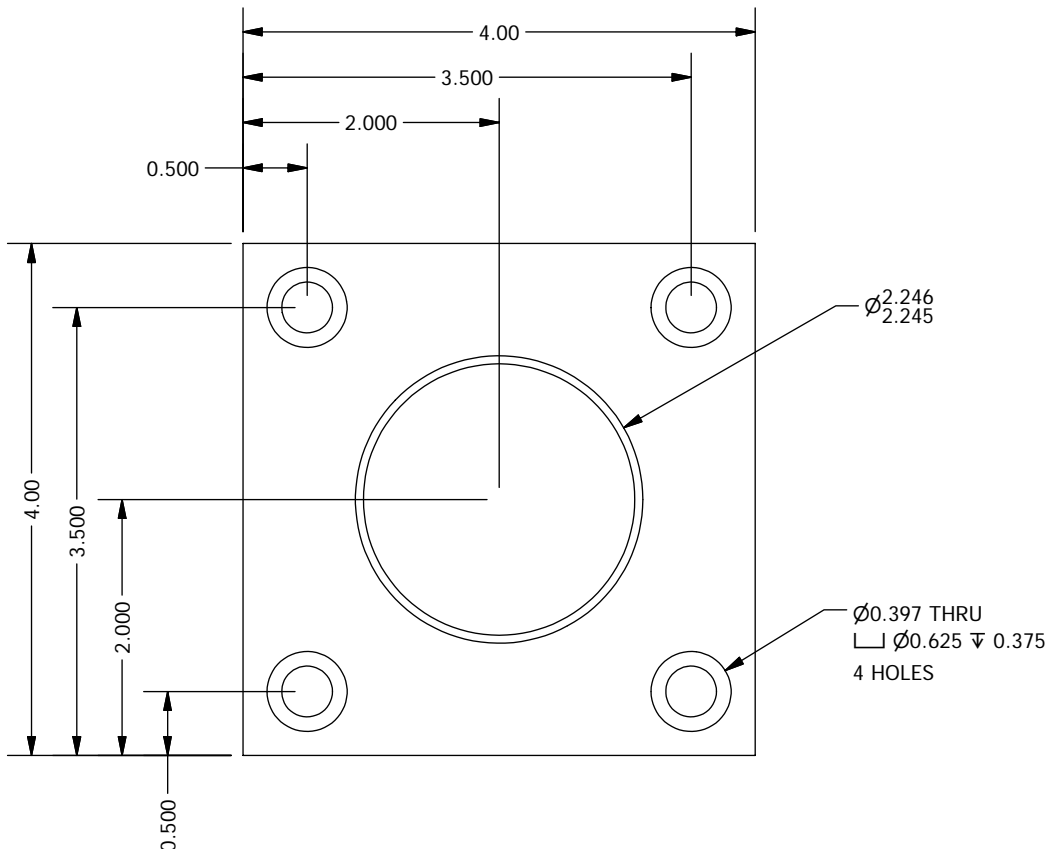

NOTES

1. Parts get epoxied to G10 tubes (PFS02012) with measured mean ID 2.2535. Nominal epoxy thickness is 0.004.

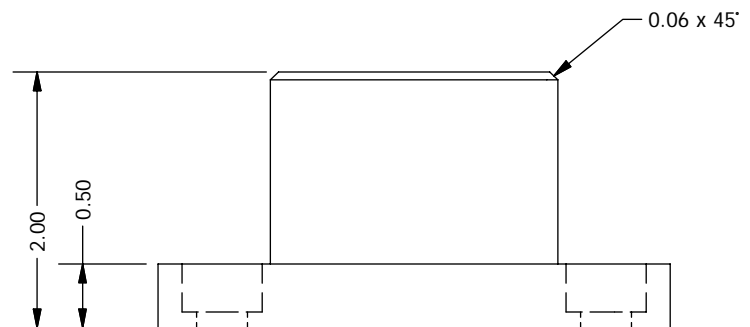

2

1

1	3	PFS02011
ITEM	QTY	DESCRIPTION
Bill of Material		
THE OBSERVATORIES OF THE CARNEGIE INSTITUTION OF WASHINGTON 813 Santa Barbara Street Pasadena, CA 91101		
MATERIAL	Steel, Mild UNLESS OTHERWISE SPECIFIED FRACTIONAL DECIMAL ANGULAR +/- 1/32 .XX +/- 0.01 +/- 0.1 DEG .XXX +/- 0.002 GOAL .XXX +/- 0.005 REQD BREAK SHARP EDGES MACHINED SURFACES 125 ✓ ALL DIMENSIONS IN INCHES	
EST WEIGHT	3.8 lb	
SCALE	2:3	
	P lanet F nder S pectrograph	Table Support Column Base
DWN	CRANE	6/13/2006
APVD		
	BY	DATE
SHEET	DRAWING NUMBER	SHT 1 OF 1
A	PFS02011	REV 1