

2

1

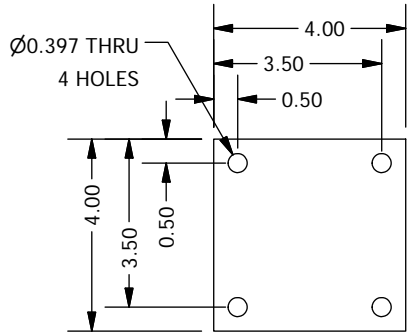

SCALE 1 / 4

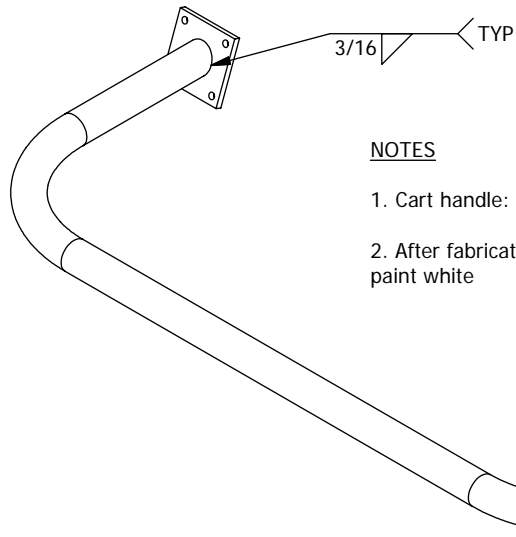
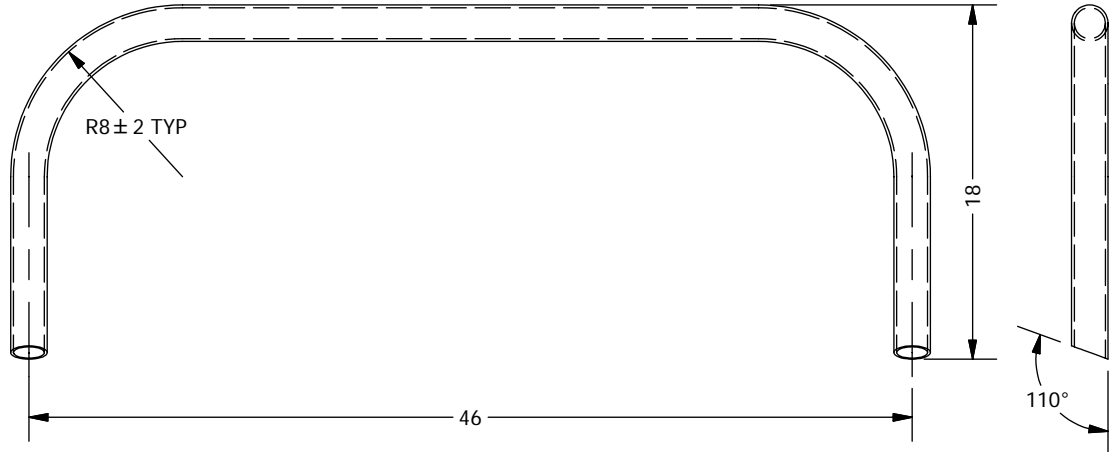

NOTES

- 1. Cart handle: (2) required
- 2. After fabrication, sandblast, prime, and paint white

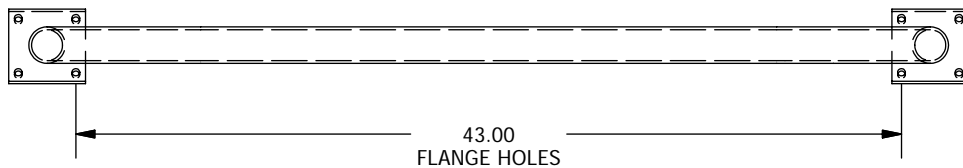
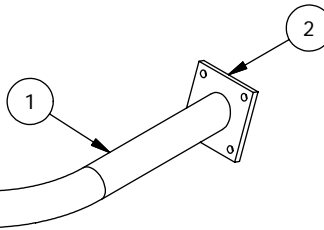

2

1

| 2 | 4 | Cart Handle Flange 4 x 4 x 1/2 Mild Steel |
|------|-----|--|
| 1 | 2 | Cart Handle Bar 1 1/2" SCH 40 PIPE (1.9" OD) |
| ITEM | QTY | DESCRIPTION |

Bill of Material

THE OBSERVATORIES
OF THE CARNEGIE INSTITUTION OF WASHINGTON
813 Santa Barbara Street
Pasadena, CA 91101

| | | | | |
|------------|-------------|---|----------------|-------------|
| MATERIAL | Steel, Mild | UNLESS OTHERWISE SPECIFIED | | |
| EST WEIGHT | 20.0 lb | FRACTIONAL | DECIMAL | ANGULAR |
| | | +/- 1/16 | .X +/- 0.1 | +/- 1/2 DEG |
| | | | .XX +/- 0.03 | |
| | | | .XXX +/- 0.003 | |
| | | BREAK SHARP EDGES MACHINED SURFACES 125 ✓ ALL DIMENSIONS IN INCHES | | |

| | | | | |
|-------|-------|------------------------------------|--|--|
| SCALE | 1:10 | P lanet F nder S pectrograph | | |
| | | Instrument Cart Handle | | |
| DWN | CRANE | 4/12/2006 | | |
| APVD | | | | |

| | | | | | | |
|--|----|------|-------|----------------|-------|-----|
| | BY | DATE | SHEET | DRAWING NUMBER | SHT 1 | REV |
| | | | A | PFS02003 | OF 1 | 1 |