

2

1

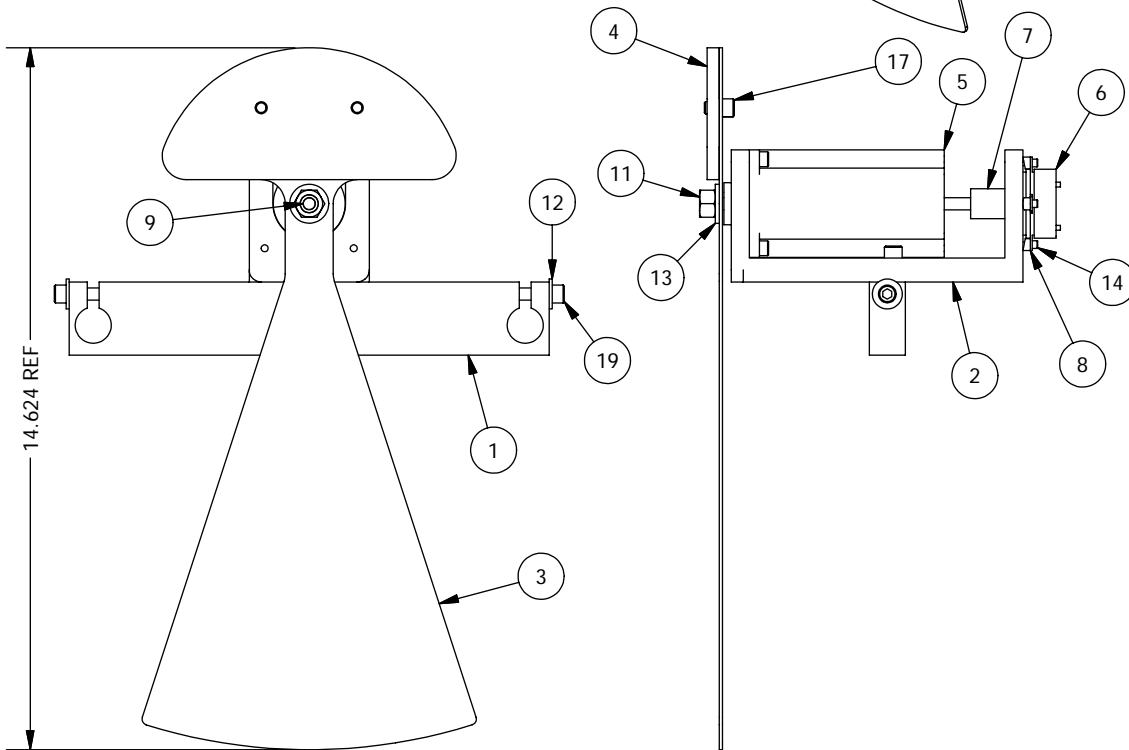
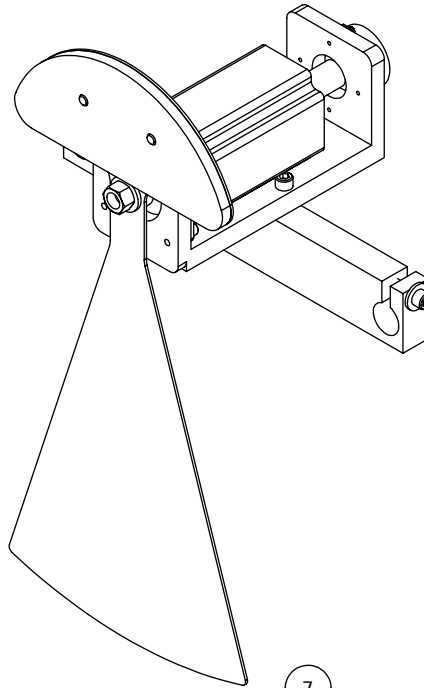
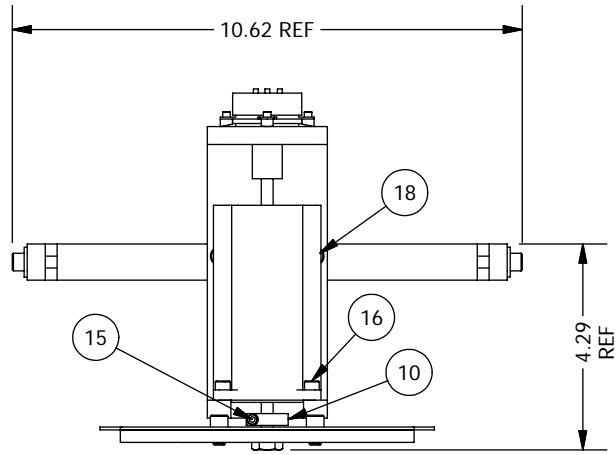

19	2	SHCS 1/4-20 UNCx1	-
18	2	SHCS 1/4-20 UNCx0.875	-
17	2	SHCS 1/4-20 UNCx0.375	-
16	4	SHCS 10-24 UNCx0.375	-
15	1	SHCS 6-32 UNCx0.375	-
14	4	SHCS 4-40 UNCx0.375	-
13	1	Washer, ANSI A, Normal 0.375	-
12	2	Washer, ANSI A, Normal 0.25	-
11	1	Hex Nut 3/8-16 UNC	-
10	1	Pic clamp L4-3	-
9	1	Pic Design K2-13 Gear Hub	-
8	4	Berg Clamp SQM-15	-
7	1	Coupling MCM6208K69	-
6	1	Maurey Instrument potentiometer 143-P93	-
5	1	Superior Electric motor KML060F03C4	-
4	1	Hartmann Mask Counterweight	PFS07004
3	1	Hartmann Mask Leaf	PFS07003
2	1	Hartmann Mask Motor Mount	PFS07002
1	1	Hartmann Mask System Flange	PFS07001
ITEM	QTY	DESCRIPTION	PART NUMBER

Bill of Material

THE OBSERVATORIES
OF THE CARNEGIE INSTITUTION OF WASHINGTON
813 Santa Barbara Street
Pasadena, CA 91101

MATERIAL		UNLESS OTHERWISE SPECIFIED FRACTIONAL DECIMAL ANGULAR +/- 1/32 .XX +/- 0.01 +/- 0.1 DEG .XXX +/- 0.002 GOAL .XXX +/- 0.005 REQD BREAK SHARP EDGES MACHINED SURFACES 125 ✓ ALL DIMENSIONS IN INCHES	
EST WEIGHT		4.8 lb	
SCALE		1:4	
		P lanet F inder S pectrograph	
		Hartmann Mask Assembly	
DWN	CRANE	5/10/2007	
APVD		SHEET	DRAWING NUMBER
	BY	DATE	
		A	PFS00020
		SHT 1 OF 1	REV 1

2

1