

SECTION A-A

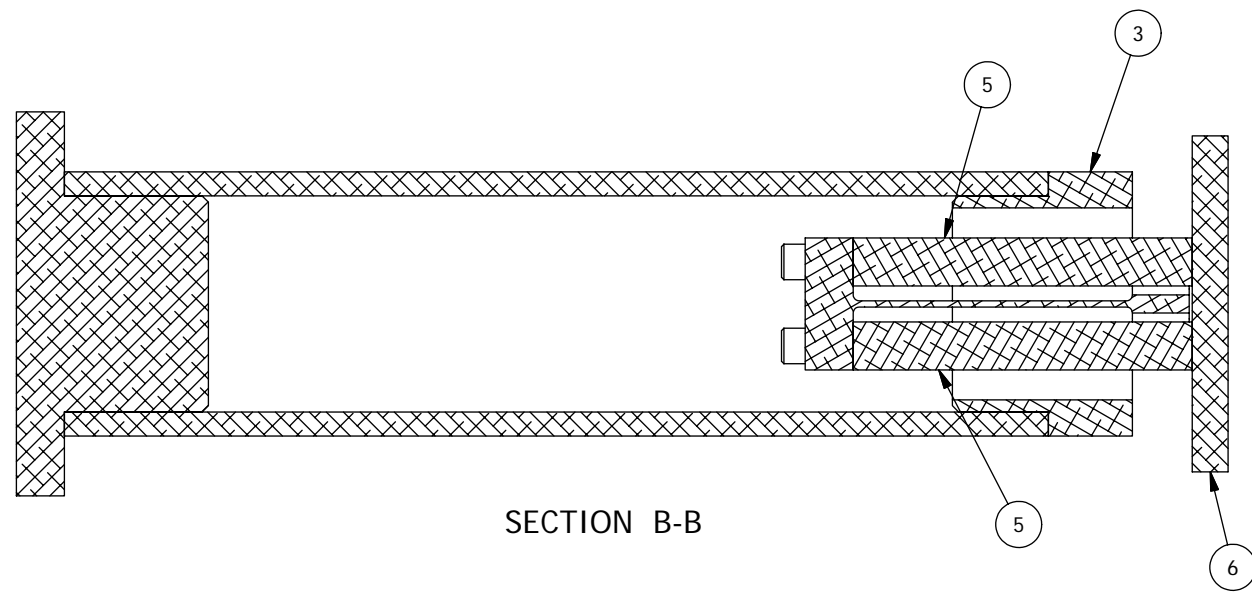

SECTION B-B

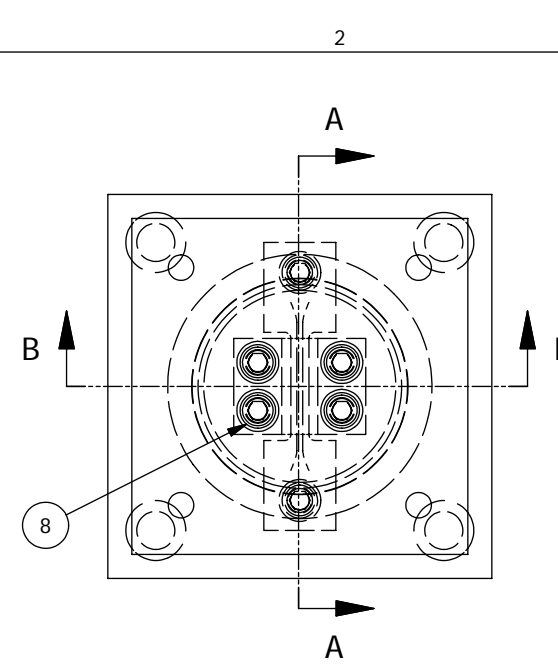

COLUMN 1

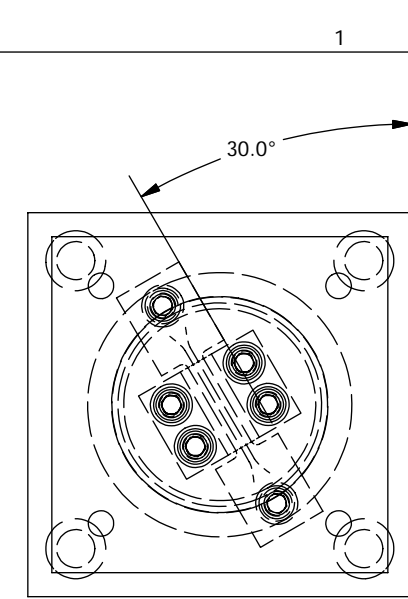

COLUMN 2

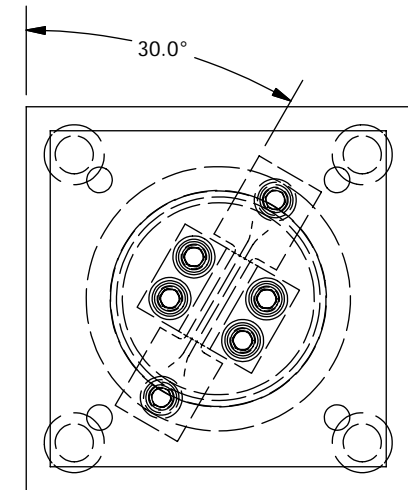

COLUMN 3

NOTES

1. Match bases and caps to individual tubes. ODs of the cylindrical extensions should be 0.008 smaller than ID of G10 tube to allow for 0.004 layer of epoxy.
2. Take care to ensure proper 0°, +30° and -30° alignments of column cap tapped flexure attachment holes for columns 1, 2, and 3, respectively. Misalignment would result in an undesirable twisting torque applied to the flexures once the optical table is attached.
3. Pending review, use Armstrong A-10 epoxy per experience of Eric Persson.
4. During instrument assembly, attach column to instrument frame (PFS02002), install lower panel of insulation, and then attach column flexures.
5. Per Steve Gunnels, it is recommended that both ends of all three epoxied G10 tube assemblies be proof loaded to 3000 lb-in.

THE OBSERVATORIES
OF THE CARNEGIE INSTITUTION OF WASHINGTON
813 Santa Barbara Street
Pasadena, CA 91101

ITEM	QTY	DESCRIPTION	PART NUMBER
9	2	SHCS 1/4-20 UNCx0.875	-
8	4	SHCS 1/4-20 UNCx0.75	-
7	4	SHCS 1/4-20 UNCx1	-
6	1	Table Support Column Flange 1/2/3	PFS02016/7/8
5	2	Table Support Column Post	PFS02015
4	1	Table Support Column Flexure	PFS02014
3	1	Table Support Column Cap	PFS02013
2	1	Table Support Column Base	PFS02011
1	1	Table Support Column Tube	PFS02012

MATERIAL		
EST WEIGHT		
SCALE		
DWN	CRANE	6/14/2006
APVD	BY	DATE

UNLESS OTHERWISE SPECIFIED		
FRACTIONAL	DECIMAL	ANGULAR
+/- 1/32	.XX +/- 0.01	+/- 0.1 DEG
.XXX +/- 0.002 GOAL		
.XXX +/- 0.005 REOD		
BREAK SHARP EDGES MACHINED SURFACES 125		
ALL DIMENSIONS IN INCHES		
P lanet F nder S pectrograph		Table Support Column Assembly
SHEET	DRAWING NUMBER	SHT 1
B	PFS00005	OF 1
REV		1

Bill of Material