

SECTION A-A

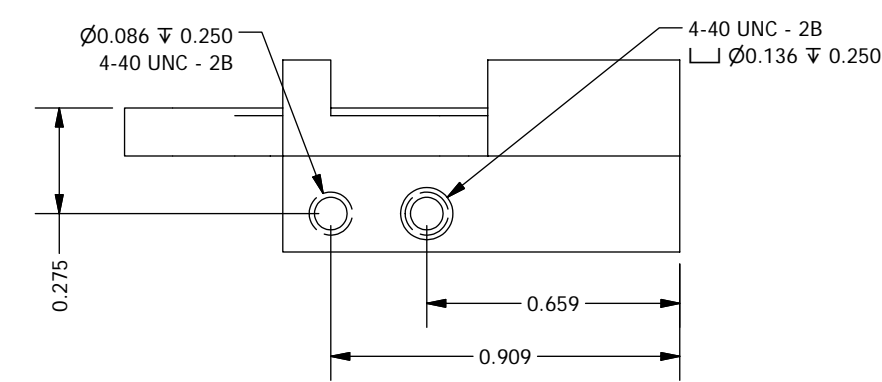

- NOTES**
1. Anodize black after machining

ITEM	QTY	DESCRIPTION
1	1	PFS06016
Bill of Material		

<b>THE OBSERVATORIES OF THE CARNEGIE INSTITUTION OF WASHINGTON</b> 813 Santa Barbara Street Pasadena, CA 91101					
MATERIAL		UNLESS OTHERWISE SPECIFIED FRACTIONAL DECIMAL ANGULAR +/- 1/32 .XX +/- 0.01 +/- 0.1 DEG			
EST WEIGHT		.XXX +/- 0.002 GOAL .XXX +/- 0.005 REQD BREAK SHARP EDGES MACHINED SURFACES 125° ALL DIMENSIONS IN INCHES			
SCALE		2:1		<b>P lanet F nder S pectrograph</b>	
DWN		CRANE	7/24/2009		
APVD		BY		DATE	<b>Slit Mask Support Frame</b>
SHEET	DRAWING NUMBER	SHT 1	REV		
B	PFS06016	OF 1	1		