

NOTES

1. Anodize black
2. Part gets epoxied to G10 tube (PFS04015). Nominal epoxy layer thickness is 0.004. Adjust Ø2.246 dimension as necessary after measurement of actual tube I.D.

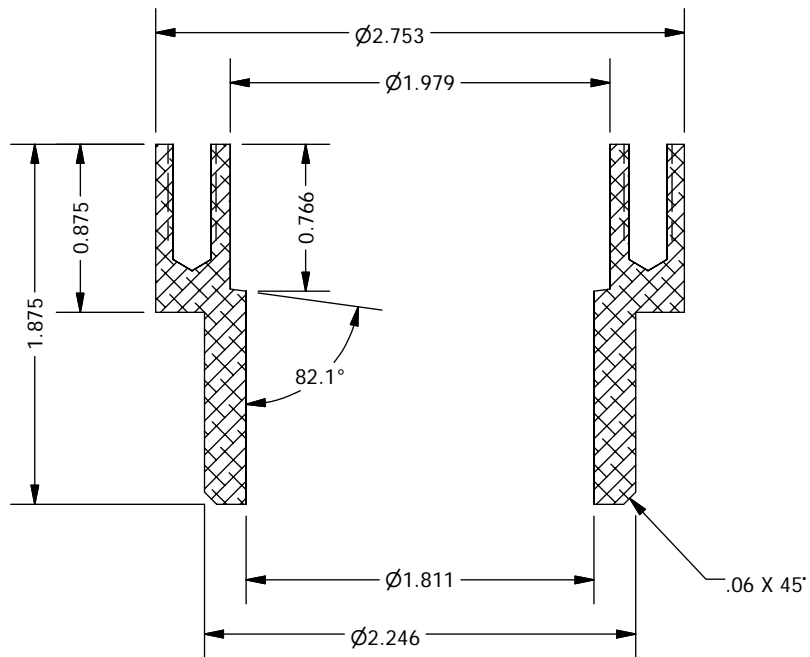

1	1	PFS04069
ITEM	QTY	DESCRIPTION
Bill of Material		
THE OBSERVATORIES OF THE CARNEGIE INSTITUTION OF WASHINGTON 813 Santa Barbara Street Pasadena, CA 91101		
MATERIAL		UNLESS OTHERWISE SPECIFIED
Aluminum-6061		FRACTIONAL DECIMAL ANGULAR
		+/- 1/32 .XX +/- 0.01 +/- 0.1 DEG
EST WEIGHT		.XXX +/- 0.002 GOAL
6.0 oz		.XXX +/- 0.005 REQD
		BREAK SHARP EDGES MACHINED SURFACES 125°
		ALL DIMENSIONS IN INCHES
SCALE		P lanet F nder S pectrograph
1:1		
		Pre Slit Support Arm Cap 3
DWN	CRANE	
APVD		
	BY	DATE
SHEET	DRAWING NUMBER	
A	PFS04069	
	SHT 1	REV
	OF 1	1