

Space for two
 $\text{Ø}25.4 \times 2.0$ mm filters
 separated by the Guider
 Filter Spacer (PFS04045)

SECTION B-B

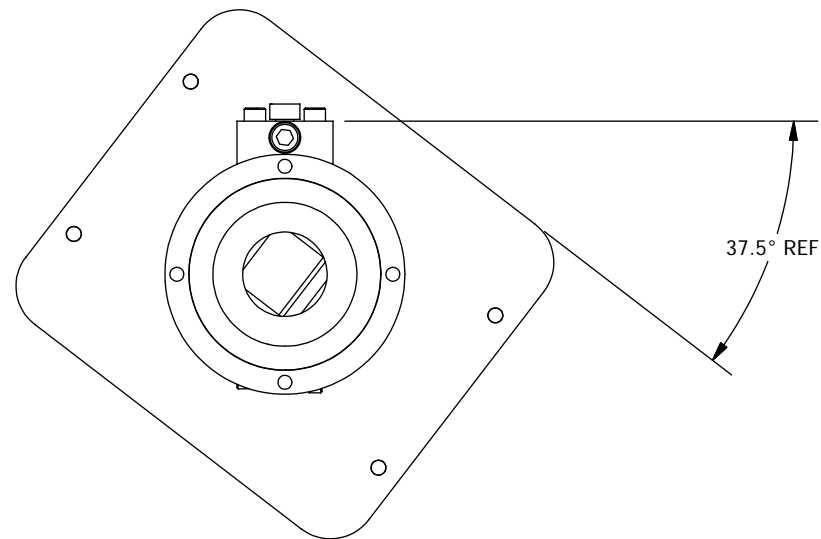
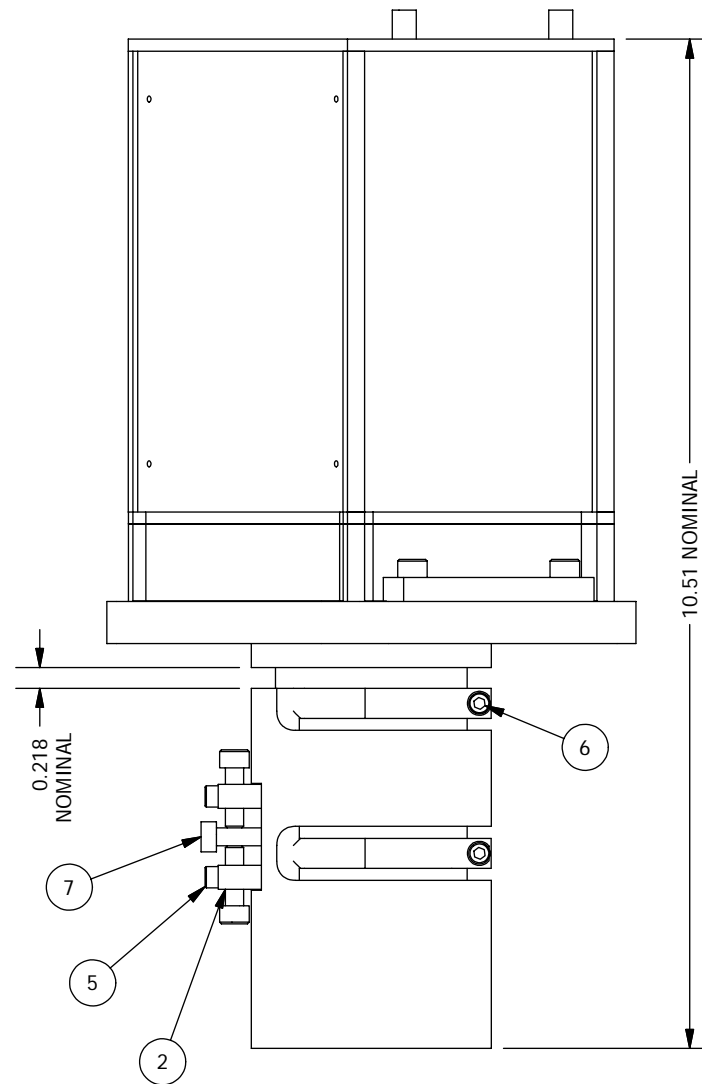
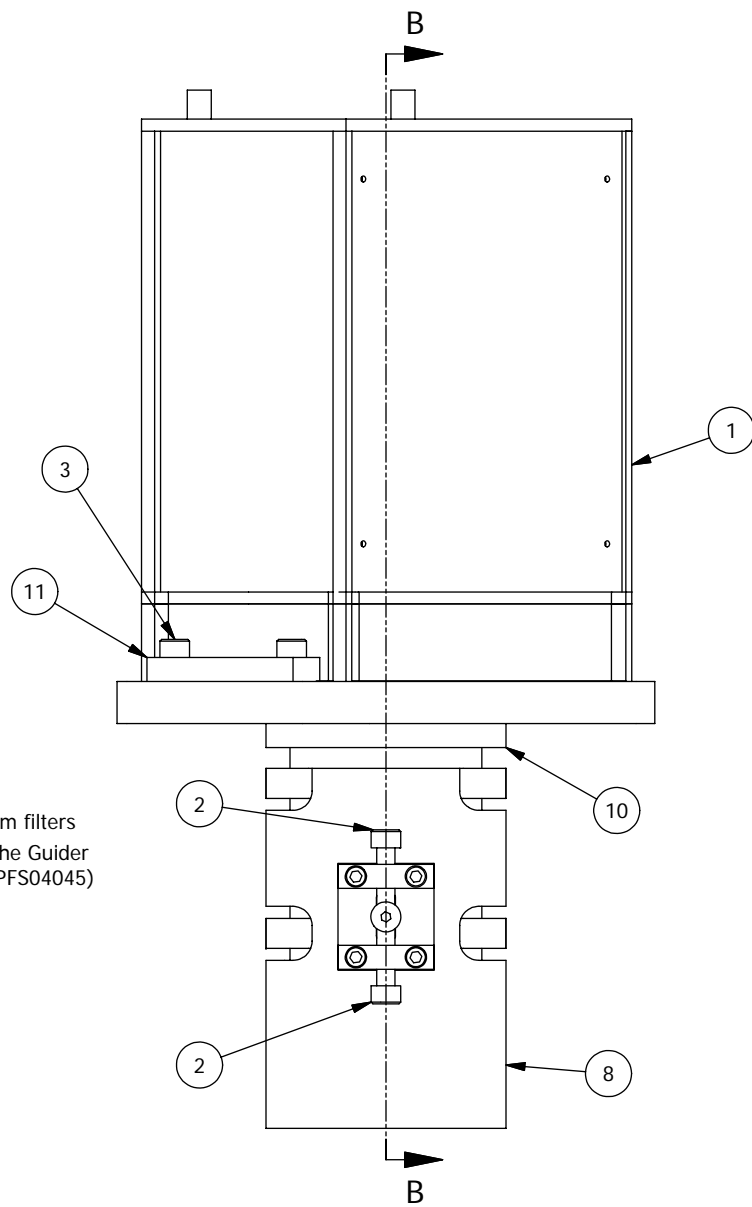

12	2	Push Block	PFS04044
11	2	Guider Clip	PFS04043
10	1	Guider Flange	PFS04042
9	1	Guider Mount Tube 2	PFS04041
8	1	Guider Mount Tube 1	PFS04040
7	1	Shoulder Screw MCM94035A206	-
6	2	SHCS 6-32 UNCx0.75	-
5	4	SHCS 6-32 UNCx0.625	-
4	4	SHCS 6-32 UNCx0.375	-
3	4	SHCS 10-32 UNFx0.625	-
2	2	SHCS 10-24 UNCx0.625	-
1	1	Guide Camera Assembly	-
ITEM	QTY	DESCRIPTION	PART NUMBER

Bill of Material

THE OBSERVATORIES
 OF THE CARNEGIE INSTITUTION OF WASHINGTON
 813 Santa Barbara Street
 Pasadena, CA 91101

MATERIAL		UNLESS OTHERWISE SPECIFIED FRACTIONAL DECIMAL ANGULAR $\pm 1/32$.XX ± 0.01 ± 0.1 DEG		
EST WEIGHT		.XXX ± 0.002 GOAL .XXX ± 0.005 REQD BREAK SHARP EDGES MACHINED SURFACES 125 $\sqrt{\text{ }}$ ALL DIMENSIONS IN INCHES		
SCALE		1:2		Planet Finder Spectrograph
DWN	CRANE	8/23/2007		Guide Camera System Assembly
APVD				
	BY	DATE	SHEET B	DRAWING NUMBER PFS00023
			SHT 1 OF 1	REV